

Heating

Cooling

Ventilation

Filtering

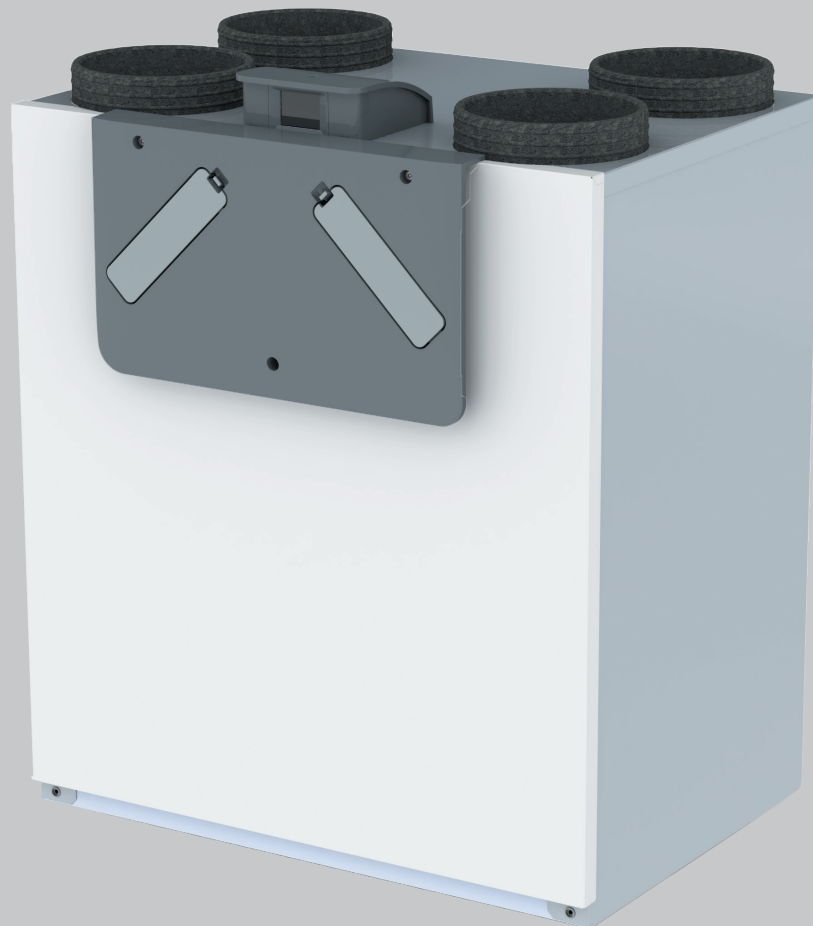



Foreword

 **Please read this manual carefully before operating the unit.**

With the help of this manual, you can install, commission or carry out maintenance on the ComfoAir E in a safe and optimal manner. The ComfoAir E is hereinafter referred to as the “unit”. As the unit is subject to continuous development and improvement, your unit may differ slightly from the descriptions in this manual.

The following symbols are used in this manual:

Symbol	Meaning
	Point of attention.
	Risk of compromised performance or damage of the ventilation system.
	Risk of personal injury.

! ? Questions

Contact the importer if you have any questions or wish to order a new manual or new filters. Contact details:

Zehnder Group Sales International • Zehnder Group Deutschland GmbH
Almweg 34 · 77933 Lahr · Germany
T +49 78 21 586-392 • F +49 78 21 586-406
sales.international@zehndergroup.com • www.international.zehnder-systems.com

Information given in the Instructions for the user

General information about the ventilation system.

Warranty and liability conditions.

EC declaration of conformity.

Replacing filters in the unit.

Cleaning the valves/grilles in the ventilation system.

Use of the display on the unit.

Information given in the Manual for the fitter

Fitting conditions.

Information on transport and unpacking.

Commissioning procedures

Installation procedures.

Available controls.

Available accessories.

Information available on the identification plate

Extension	Meaning
ComfoAir E	Product family name
350	Maximum air capacity: 350 m ³ /h.
R	The dwelling side is installed at the factory as standard on the right-hand side of the unit.
L	The dwelling side is installed at the factory as standard on the left-hand side of the unit.
VL/VR	The unit is supplied by the factory with a preheater

All rights reserved.

This manual has been compiled with the utmost care. The publisher cannot be held liable for any damage caused as a result of missing or incorrect information in this document. In case of disparity, the English text takes precedent.

Contents

	Foreword	2
1	Safety instructions	4
2	Service procedures	5
	2.1 Overview of the display	5
	2.2 Service menu	6
	2.3 Explanation of the SERVICE MODE menu	7
	2.4 Programming air specifications	8
	2.5 RF controls.....	9
	2.6 Explanation of VENTILATION SETTINGS menu	10
	2.7 Explanation of REPLACE FILTER warning	10
	2.8 Explanation of ALTITUDE menu.....	10
	2.9 Explanation of TEMPERATURE menu	10
	2.10 Explanation of FANS menu.....	10
	2.11 Explanation of UNIT SPECIFICATION menu	11
	2.12 Explanation of the BALANCE SETTING menu.....	11
	2.13 Explanation of ANALOGUE 0-10 V menu (standard) and RF SETTING (optional)	11
	2.14 Explanation of the PREHEATER menu	11
	2.15 Explanation of the SYSTEM TEST menu	12
	2.16 Explanation of RESTORE TO FACTORY SETTINGS menu	12
	2.17 Explanation of control methods.....	12
3	Technical specifications.....	14
	3.1 Service parts	16
	3.2 Connection diagram	17
	3.3 Dimension sketch	19
4	Maintenance procedures	20
	4.1 Procedure for opening the unit	20
	4.2 Maintenance of the casing	21
	4.3 Maintenance of the heat exchanger.....	21
	4.4 Maintenance of the bypass flaps	22
	4.5 Maintenance of the fans.....	23
	4.6 Maintenance of the preheater.....	24
	4.7 Maintenance of the condensation drain:	25
	4.8 Maintenance of the air ducts	25
	4.9 Procedure for completing maintenance.....	25
5	Malfunction procedures	26
	5.1 Malfunction alerts on the display of the unit	26
	5.2 Access to the control PCB.....	27
	5.3 Changing the installation position of the preheater	27
	5.4 Access to the T11/T20 sensor.....	28
	5.5 Access to the T12/T21/T22 sensor.....	29
	5.6 Resetting errors	29
	5.7 Carrying out a system test.....	29
	5.8 What to do if a malfunction alert occurs (problem solving).....	30
	5.9 What to do if a malfunction (or problem) occurs without error alert (problem solving).....	35

1 Safety instructions

- Always comply with the safety regulations in this document. Failure to comply with the safety regulations, instructions, warnings and comments may lead to personal injury or damage to the unit.
- Always observe the local building, safety and installation guidelines of the municipality, utility companies or other authorities;
- Always connect air ducts with a minimum length of 900 mm to the unit before connecting the power supply to prevent contact with the rotating fans.
- After installation, all parts that could lead to personal injury are safely out of reach behind the casing. The ComfoAir cannot be opened without using tools.
- It is not permitted to modify the unit or any of the specifications contained in this document. This may result in personal injury or reduced ventilation system performance.
- Installation, commissioning and maintenance must be carried out by a certified person or company, unless stated otherwise. If this work is carried out by unauthorised persons, it may result in personal injury or reduced performance of the ventilation system.
- Always unplug the power cord before starting any work on the unit. Using the unit with the casing open may result in personal injury. In this case, make sure that no conductive or rotating parts can be touched.
- Static charge can damage the electronics. When working with electronics, always take protective measures to prevent electrostatic discharge, such as wearing an antistatic wristband.
- If the power cord is damaged, it must be replaced by the manufacturer, the service engineer or a qualified person to avoid risks.

Power supply diagram

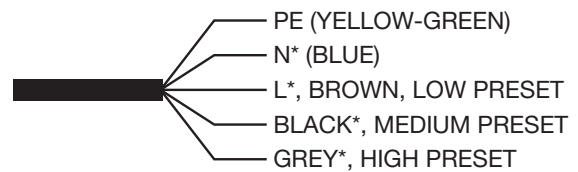

* Disconnect these poles for servicing

2 Service procedures

2.1 Overview of the display





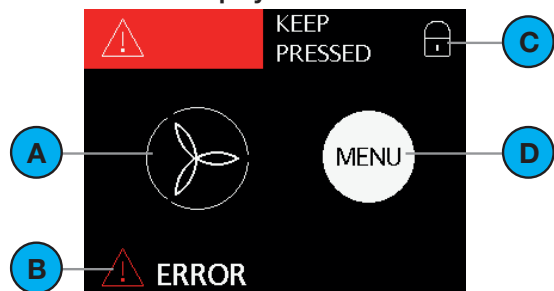

The unit has a touchscreen display for readout and programming the unit.

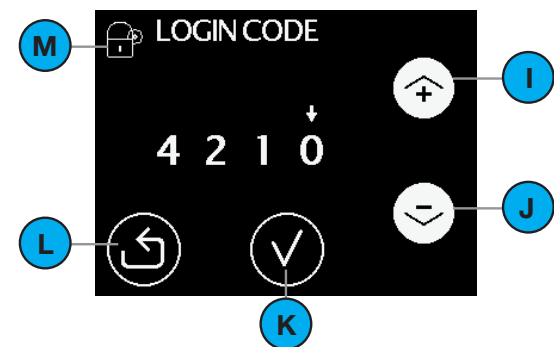
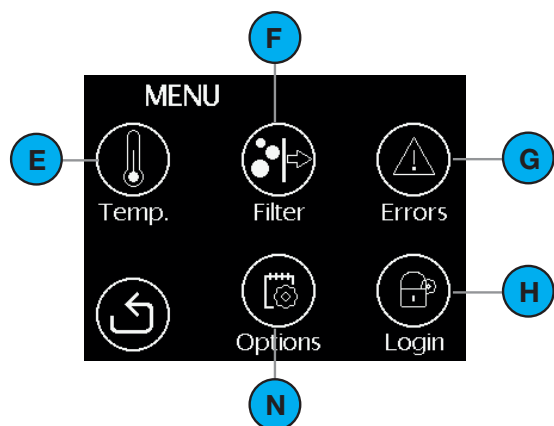
Main screen of display



Menu screen of display



#	Explanation
A	Current airflow: <ul style="list-style-type: none"> ■ No icon = No ventilation ■  = LOW SETTING; ■  = MEDIUM SETTING; ■  = HIGH SETTING;
B	Current status: <ul style="list-style-type: none"> ■  Green = The unit is operating correctly; ■  Orange = Replace filters; ■  Red = Malfunction.
C	Child lock is engaged.
D	Icon for activating the menu screen.
E	Icon for activating the comfort temperature menu.
F	Icon for activating the filter replacement menu.
G	Icon for activating the error readout menu.
H	Icon for activating the installer/service menu.
I	Arrow up: <ul style="list-style-type: none"> ■ Increase value; ■ To previous error alert.
J	Arrow down: <ul style="list-style-type: none"> ■ Decrease value; ■ To next error alert.
K	Selection check box for activating the text shown. Any changes are saved.
L	Arrow to return to the previous screen. Any changes are NOT saved.
M	Identification menu for the fitter / service engineer.
N	Icon for activating the option menu.

2.2 Service menu

The service menu lists all the steps required for commissioning the unit and tracing the causes of any malfunction.

The service menu is protected by a password (4210) that remains active for at least 15 minutes. Each number of the password must be entered individually with the arrow keys and confirmed with the confirmation key.



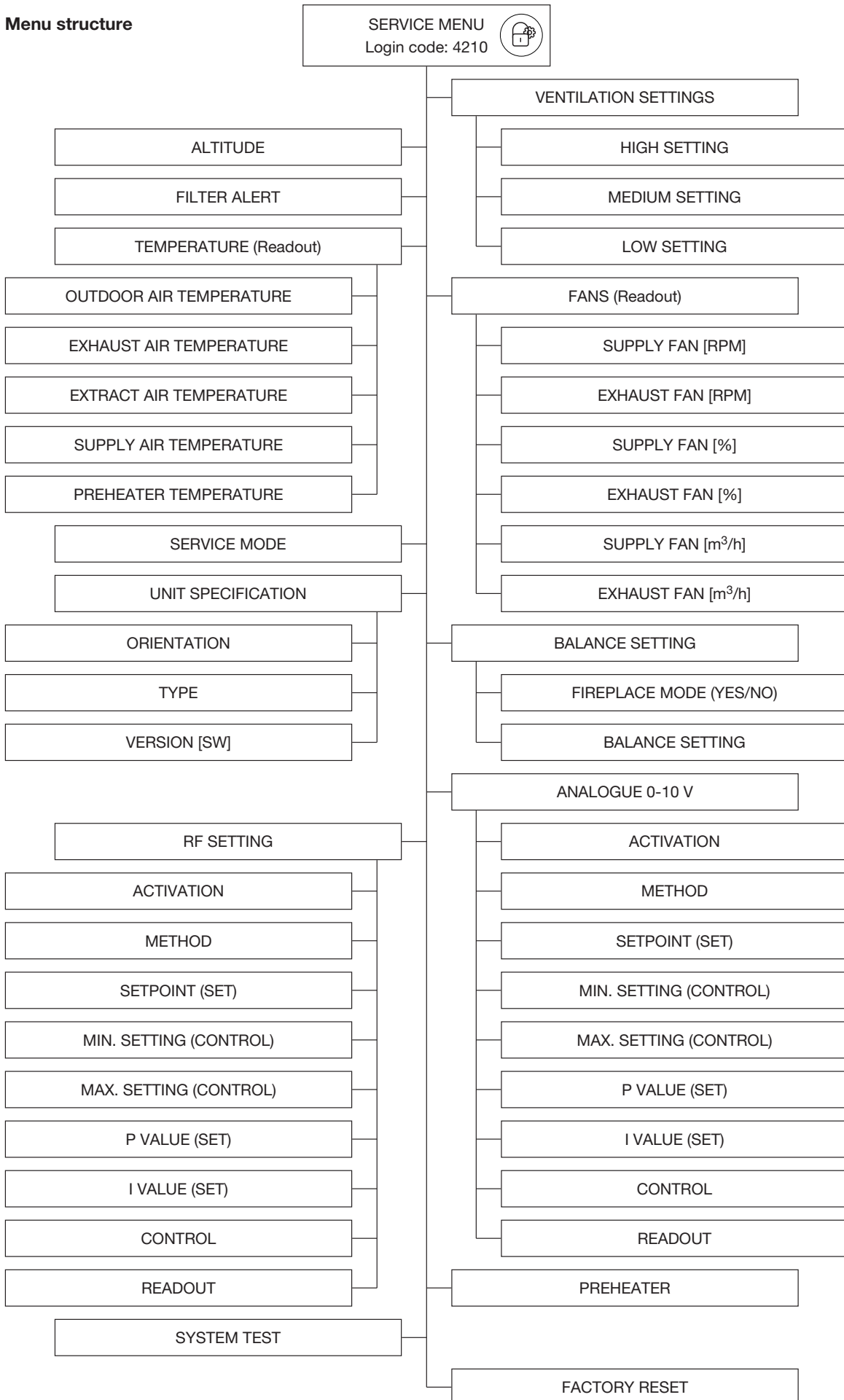











Menu structure

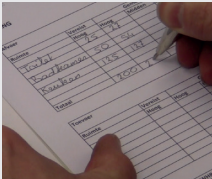

2.3 Explanation of the SERVICE MODE menu

To enable maintenance of the unit, it is fitted with a SERVICE MODE. By activating this mode, the basic functions of the unit are deactivated and the bypass valves of the heat exchanger are removed. To prevent electrically charged parts being touched, the power must still be manually disconnected from the unit after setting the SERVICE MODE. Once the power is reconnected to the unit, the SERVICE MODE will be deactivated automatically. Also the service menu password will have to be re-entered.

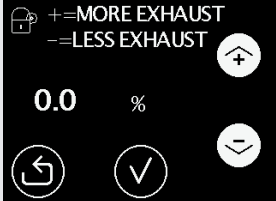



2.4 Programming air specifications

<p>1</p> 	<p>2</p> 	<p>3</p> 
<p>Close all windows and doors. Open all valves connected to the ventilation system via the ducts.</p>	<p>Connect the device to the mains. Select a language and confirm that the siphon is mounted correctly. Check the above illustration for more information about the installation of the siphon.</p>	<p>Go to the settings for the installer. (MENU > Login; Login code= 4210)</p>
<p>4</p> 	<p>5</p>  <p>The fans will automatically start rotating to the set position. The unit is in the commissioning mode for one hour.</p>	<p>6</p> 
<p>Set the required total air flow to the maximum flow rate. (MENU>Login>VENTILATION SETTINGS>HIGH SETTING)</p> <p> = Air flow almost at limit value</p> <p> = Air flow insufficient</p> <p>If the limit value is lower than the desired air flow, a further system test must be carried out. (MENU>Login>SYSTEM TEST) For more information, see chapter 2.15.</p>	<p>Press  to switch the commissioning mode off again directly without saving the value entered.</p> <p>Press  to save the value entered.</p> <p>REPEAT THESE STEPS FOR THE MEDIUM AND LOW SETTINGS</p>	<p>Measure the air flow at each opened valve using a flow meter. Write down the air flow for these valves. Adjust the opened valves to the required air flow per room. Measure the air flow again at each opened valve using a flow meter. Check that the air flow complies with the standard for each opened valve.</p>
<p>7</p> 	<p>8</p> 	<p>9</p> 
<p>If the air flow is fine everywhere: Press  to exit the commissioning mode. Complete an installation/test report. An example can be found in the back of the user manual.</p>	<p>The unit's installation height must be specified in the "ALTITUDE" menu. (MENU>Login>ALTITUDE>)</p>	<p>In the menu BALANCE SETTING an unbalance between supply and exhaust air can be set. (MENU>Login>BALANCE SETTING>BALANCE FINE TUNE)</p> <p>BALANCE SETTING selection: '+=' more exhaust air; '-=' less exhaust air. With the FIREPLACE MODE setting activated, only less exhaust air (='-') is possible.</p> <p>FROST PROTECTION selection (without preheater): (BALANCE SETTING>FIREPLACE MODE)</p> <ul style="list-style-type: none"> ■ FIREPLACE MODE active? YES: (Default) Exhaust and supply air remain in balance at all times. As a result, the unit switches off faster in frost mode than in inactive fireplace mode. ■ FIREPLACE MODE active? NO: There is more supply air than exhaust air. So in frost mode, ventilation is maintained longer.

 **Malfunctions of the preheater or bypass can only be reset after the system test has been carried out again.**

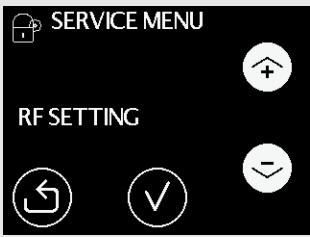
2.5 RF controls

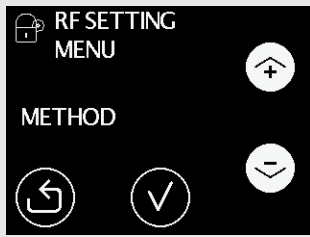
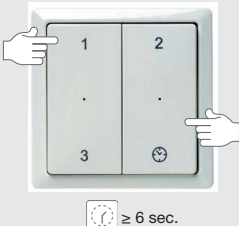
To enable the use of RF controls, the unit needs to be equipped with an RF PCB. The RF PCB has to be ordered separately and can be installed later on.

<p>1</p> 	<p>2</p> 	<p>3</p> 
<p>If RF ACTIVATION is set to ON: Set the RF ACTIVATION on the display of the unit to OFF. (MENU>SERVICE MENU>RF SETTING>ACTIVATION>OFF)</p> <p>The power will now be removed from the RF PCB.</p>	<p>Set the RF ACTIVATION on the display of the unit to ON. (MENU>SERVICE MENU>RF SETTING>ACTIVATION>ON)</p> <p>You now have 10 minutes to register the RF control.</p>	<p>Set METHOD on the display of the unit to DISCRETE CONTROL (MENU>SERVICE MENU>RF SETTING>METHOD>DISCRETE CONTROL)</p>
<p>4</p>  <p>$\geq 6 \text{ sec.}$</p>		
<p>RFZ: Press button "1" & and button "☺" together for at least 6 sec.</p>	<p>The airflow rate of the unit changes (see the unit's display): Registering successful.</p> <p>The airflow rate of the unit does not change (see the unit's display): Return to step 1.</p>	

 **Each RF control must be registered separately.**
For each extra RF control, return to step 1.

2.6 Explanation of VENTILATION SETTINGS

menu

The building regulations describe how much fresh supply air must be provided to each room. The VENTILATION SETTINGS must be programmed in such a way that the unit can supply the maximum necessary volume of fresh air for the entire building. If only HIGH SETTING is programmed, the unit will automatically set MEDIUM SETTING to 66% of HIGH SETTING, and LOW SETTING to 33% of HIGH SETTING. If MEDIUM SETTING or LOW SETTING is programmed, this automatic link will be lost. To recover the link, all the unit's FACTORY SETTINGS must be restored via the FACTORY RESET function.

FACTORY SETTINGS	
ComfoAir E	350
HIGH SETTING	315 m ³ /h
MEDIUM SETTING	205 m ³ /h
LOW SETTING	105 m ³ /h

Once the settings screen or valve setup screen is visible, the unit switches off all automatic programmes and runs on the set value so that all valves can be properly set. After touching the screen, you have 60 minutes to set all valves. The unit then switches back automatically to the normal operating mode and the main screen. Every time the screen is touched, the 60-minute timer is reset. If the settings screen or valve setup screen is exited manually, the unit returns directly to the normal operating mode and after 15 minutes without being touched the unit returns automatically to the main screen.

2.7 Explanation of REPLACE FILTER warning

The filter warning appears by default 21 days before the filters need to be replaced. This gives the user enough time to purchase new filters before the dirty filters are to be replaced. It is possible to set the alert to appear earlier by increasing the number of filter order days in the service menu FILTER ALERT. The filters must be replaced at least once every 180 days.

2.8 Explanation of ALTITUDE menu

This value compensates for the influence of altitude on the air volume. In the "Altitude" menu, the altitude of the installation location of the unit must be specified.

2.9 Explanation of TEMPERATURE menu

The unit is equipped with 5 temperature sensors. The readout of the current value of these sensors appears in the TEMPERATURE menu in the sequence given below.

	Meaning
OUTDOOR AIR TEMPERATURE (TEMP SENSOR T20)	Outdoor air temperature prior to the preheater
EXHAUST AIR TEMPERATURE (TEMP SENSOR T12)	Exhaust air temperature
EXTRACT AIR TEMPERATURE (TEMP SENSOR T11)	Extract air temperature
SUPPLY AIR TEMPERATURE (TEMP SENSOR T22)	Supply air temperature
PREHEATER TEMPERATURE (TEMP SENSOR T21)	Outdoor air temperature after the preheater.

2.10 Explanation of FANS menu

The unit is equipped with 2 fans. The readout of the current value of these fans appears in the FANS menu in the sequence given below.

	Meaning
SUPPLY FAN [RPM] (FAN 22)	Speed of the supply fan.
EXHAUST FAN [RPM] (FAN 12)	Speed of the exhaust fan.
SUPPLY FAN [%] (FAN 22)	Control percentage (fan duty) of the supply fan.
EXHAUST FAN [%] (FAN 12)	Control percentage (fan duty) of the exhaust fan.
SUPPLY FAN [m ³ /h] (FAN 22)	Airflow rate (flow) of the supply fan.
EXHAUST FAN [m ³ /h] (FAN 12)	Airflow rate (flow) of the exhaust fan.

2.11 Explanation of UNIT SPECIFICATION menu

In the UNIT SPECIFICATION menu, the readout of the basic unit details appears in the sequence below.

	Meaning
ORIENTATION	Show the current orientation of the unit: <ul style="list-style-type: none"> ■ RIGHT UNIT has the air connectors that enter the home on the left-hand side and the siphon connector to the right; ■ LEFT UNIT has the air connectors that enter the home on the right-hand side and the siphon connector to the left;
TYPE	Show the current version of the unit <ul style="list-style-type: none"> ■ ComfoAir E 350 indicates that the unit has a maximum air capacity of 350 m³/h; ■ VL/VR indicates that the unit is supplied from the factory with a preheater
VERSION	Indicates that current software version.

2.12 Explanation of the BALANCE SETTING menu

The unit is equipped with a constant volume control which ensures that the same amount of air is supplied as is extracted. The unit thus factors in the difference in duct resistance. Leave this value in the menu at 0%, so both airflows are always in balance.

In the “Balance setting” menu, an unbalance between supply air and extract air can be set.

(MENU>Login>BALANCE SETTING>BALANCE SETTING)

Select BALANCE SETTING

‘+’ = more extract air ; ‘-’ = less extract air; when fireplace control is activated, only less extract air (= ‘-’) is possible.

Select frost protection (without preheater)
(Balance setting > Fireplace mode)

- Fireplace mode active? YES: (Standard) Extract air and supply air always remain in balance. This will cause the unit to switch off sooner in frost conditions than in inactive fireplace mode.
- Fireplace mode active? NO: More extract air than supply air is conveyed. This ensures longer operation in frost conditions until deactivation.

2.13 Explanation of ANALOGUE 0-10 V menu (standard) and RF SETTING (optional)

The unit can be controlled with any analogue 0-10 V signal and/or an RF signal. To ensure the control runs properly, the following parameters can be set in the sequence given below.

	Meaning
ACTIVATION	<ul style="list-style-type: none"> ■ ON indicates that the unit should detect a 0-10 V or RF signal; ■ OFF indicates that the unit does not have to detect a 0-10 V or RF signal.
METHOD	<ul style="list-style-type: none"> ■ DISCRETE CONTROL indicates that the unit must process the 0-10 V or RF signal as a control signal using 3 steps; ■ CONTROL indicates that the unit must process the 0-10 V or RF signal as a control signal; ■ SET indicates that the unit must process the 0-10 V or RF signal as a regulate signal.
SETPOINT ¹	The setpoint at which the unit starts regulating.
MIN. SETTING. ²	The minimum incoming value the unit must use to exercise control. (LOW SETTING)
MAX. SETTING. ²	The maximum incoming value the unit must use to exercise control. (HIGH SETTING)
P VALUE ¹	The proportional bandwidth value at which the unit starts regulating.
I VALUE ¹	The integration point at which the unit starts regulating.
CONTROL	<ul style="list-style-type: none"> ■ POSITIVE indicates that the unit must speed up at a higher control value or a too low regulation value; ■ NEGATIVE indicates that the unit must slow down at a higher control value or a too low regulation value.
READOUT	The currently incoming 0-10 V or RF signal.

¹ Only relevant if SET METHOD is selected.

² Only relevant if CONTROL METHOD or DISCRETE CONTROL METHOD is selected.

2.14 Explanation of the PREHEATER menu

In the PREHEATER menu, the use of a preheater can be set.

If no preheater is present, the unit switches to “Frost protection without preheater” in frost mode.

2.15 Explanation of the SYSTEM TEST menu

A system test can be initiated in the SYSTEM TEST menu.

(MENU>Login>SYSTEM TEST)

	Meaning
SYSTEM TEST CANCELLED MAX. BELOW 150 m ³ /h	<p>This error must be resolved in order to carry out a system test. Otherwise errors of the preheater or bypass cannot be resolved!</p> <p>Possible causes:</p> <ul style="list-style-type: none"> ■ HIGH SETTING set lower than 160 m³/h ■ Air volume of valves not set correctly (valves too tight) ■ Air ducts have too much resistance ■ Outdoor air grille blocked ■ ALTITUDE entered incorrectly ■ Filters are dirty ■ Heat exchanger is frozen
Preset 3 supply air (m ³ /h) ACTUAL (SETTING)	<p>The air volume on the supply side (ODA & SUP) is set lower. Accept this or reduce the air resistance on the supply side of the system. Then carry out another system test.</p> <p>Possible causes:</p> <ul style="list-style-type: none"> ■ Air volume of valves not set correctly (valves too tight) ■ Air ducts have too much resistance ■ Outdoor air grille blocked ■ ALTITUDE entered incorrectly ■ Filters are dirty
Preset 3 extract air (m ³ /h) ACTUAL (SETTING)	<p>The air volume is lower than set on the extract side (ETA & EHA). Accept this or reduce the air resistance on the extract side of the system. Then carry out another system test.</p> <p>Possible causes:</p> <ul style="list-style-type: none"> ■ Air volume of valves not set correctly (valves too tight) ■ Air ducts have too much resistance ■ ALTITUDE entered incorrectly ■ Filters are dirty ■ Heat exchanger is frozen

2.16 Explanation of RESTORE TO FACTORY SETTINGS menu

The factory settings of the unit are permanently saved to the control PCB. Using the RESTORE TO FACTORY SETTINGS menu, the unit can be switched back to the factory settings. This permanently overwrites all adjusted settings. After the reset, the unit will start running as if it had just left production. The air specifications, analogue input and RF controls (if unit is equipped with) will have to be reset/re-programmed.

If only the malfunction codes need to be reset, then use the reset function in menu errors on the first menu screen.

2.17 Explanation of control methods

What is SET METHOD?

Regulating involves maintaining the programmed set point. If the incoming signal of the desired set point deviates, the unit will adapt the outgoing signal to arrive at the desired set point.

What is POSITIVE?

In the event of positive regulating, power will go up if the measurement is below the set point. In the event of a higher measurement, power will go down. Most of the pressure sensors use positive regulating.

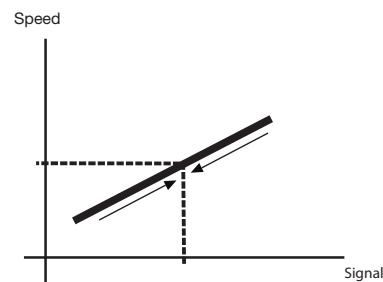

What is NEGATIVE?

In the event of negative regulating, power is increased if the measurement is higher than the set point. In the event of a lower measurement, power is decreased.

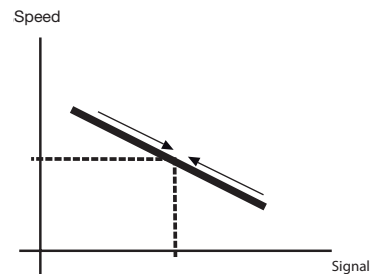

What is the METHOD CONTROL?

With this method, an incoming signal generates a standard outgoing signal.

What is POSITIVE?

With positive control, a higher input signal generates a higher output signal.

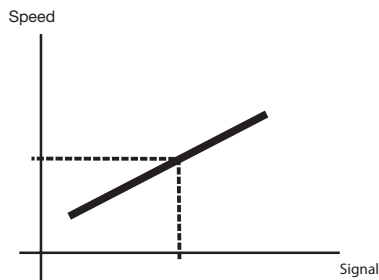

What is NEGATIVE?

With negative control, a higher input signal generates a lower output signal.

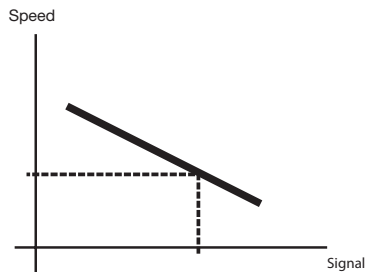

What is the METHOD DISCRETE CONTROL?

With separate control, the output signal generates one of the programmed VENTILATION SETTINGS.

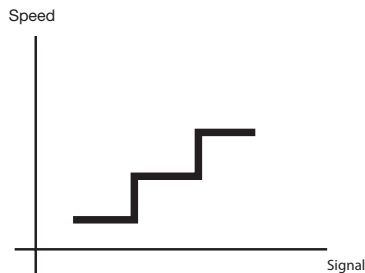

- Input signal < 4 V = Setting 1
- Input signal between 4 V and 7 V = Setting 2
- Input signal >7 V = Setting 3

What are the P VALUE and the I VALUE for (PI Controller)?

Proportional means that the difference between the desired and measured value is increased by the value k.
Integral means that the error is constantly summed and that the unit continues to transmit more signals depending on how long an error lasts between the measured and desired value. (The time required to obtain the same value as the P action. A small time value results in a strong I action.)

3 Technical specifications

ComfoAir E350			
Performance			
Minimum airflow if preheater on	100 m ³ /h		
Minimum airflow if preheater off	50 m ³ /h		
Maximum airflow	350 m ³ /h		
Heat efficiency level ¹	91%		
Electrical connection details			
Maximum performance/power without preheater ²	120 W	1.03 A	
Maximum performance/power with preheater ²	1580 W	7.38 A	
Power supply	230 V ± 10%, single phase, 50 Hz		
Cos φ	0.34 - 0.51		
Mechanical connection details			
Dimensions of air connection (Ø)	Internal: 160 mm External: 190 mm		
Dimensions of condensation drain (Ø)	32 mm		
Material specifications			
Casing	Coated sheet steel		
Inner surface	EPP and ABS		
Heat exchanger	Polystyrene		
General			
Temperature range during transport and storage	-20°C to +50°C		
Temperature range moved air	-15°C to +50°C		
Temperature range of installation area	>8°C (is not a range)		
Relative humidity of installation area	<90% (non-condensing)		
IP classification	IP 41		
ISO classification	B		
Weight	50 kg		
Filter class	ISO Coarse and ISO ePM1 according to ISO 16890 (G4/F7)		

Temperature sensor preheater			
Type	10k NTC KTY 81-210		
Test range	-40°C to +70°C		
Temperature °C	Resistance MINIMUM SETTING kΩ	Resistance MEDIUM SETTING kΩ	Resistance MAXIMUM SETTING kΩ
10	19.57	19.90	20.24
15	15.48	15.71	15.94
18	13.50	13.68	13.86
19	12.90	13.07	13.23
20	12.33	12.49	12.64
21	11.80	11.94	12.08
22	11.29	11.42	11.55
25	9.90	10.00	10.10
30	7.95	8.05	8.15

ComfoAir E 350

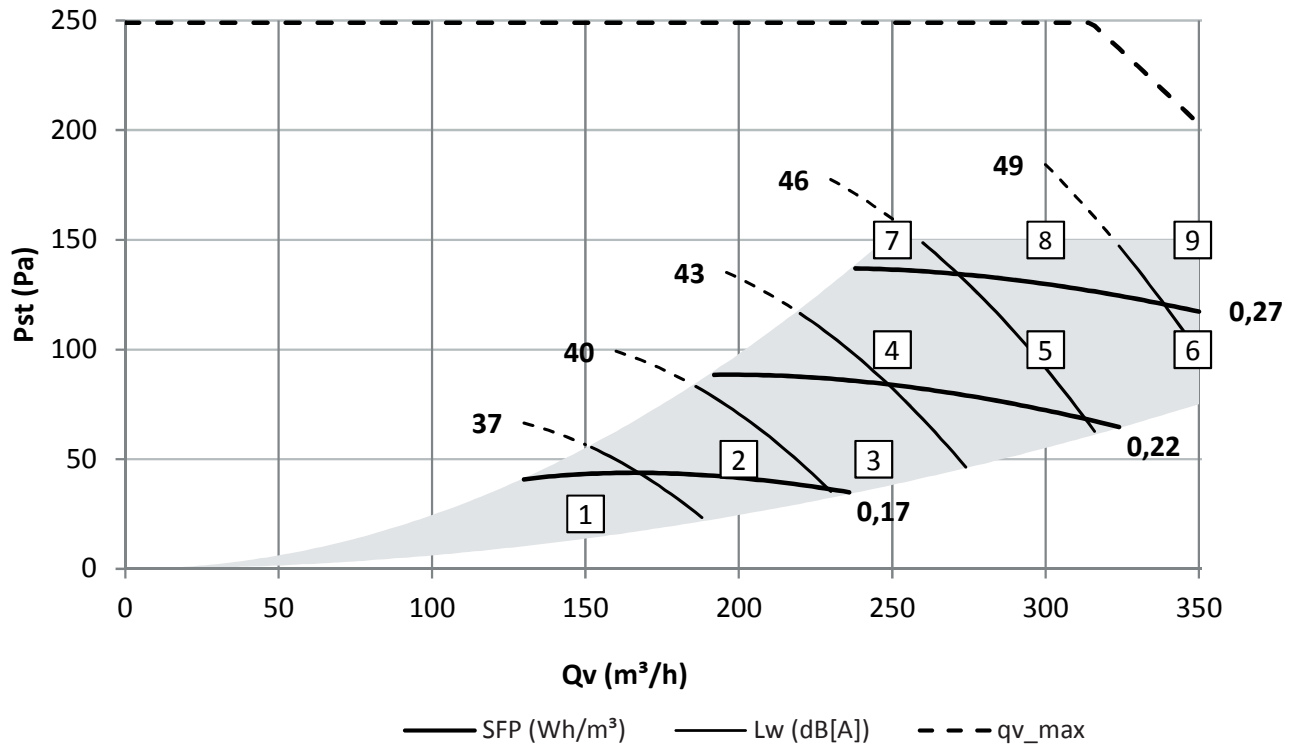

	Qv m³/h	Pst Pa	P W	cos φ	SFP Wh/m³	Lw, supply dB(A)	Lw, return dB(A)	Lw, casing dB(A)
1	150	25	22	0.38	0.15	49	36	34
2	200	50	36	0.42	0.18	53	40	38
3	245	50	46	0.44	0.19	56	42	41
4	250	100	59	0.46	0.24	59	44	43
5	300	100	73	0.47	0.24	62	47	46
6	350	100	90	0.48	0.26	65	49	49
7	250	150	71	0.47	0.28	61	46	45
8	300	150	86	0.48	0.29	63	48	48
9	350	150	104	0.49	0.30	66	51	50

Lw in dB(A) reference 10⁻¹² W

Cabinet emission tested as per ISO 3741: 2010

Supply and return noise level tested as per ISO 5135: 1997 (values are with end-reflection correction)

SFP in Wh/m³ calculated based on the details as per EN13141-7: 2010

Cos φ with preheater deactivated

3.1 Service parts

The service parts stated below may be ordered as a special service set from Zehnder.

Each set contains an instruction that explains how to replace the part.

Refer to the price list from your supplier for the item codes and the prices of all available sets.

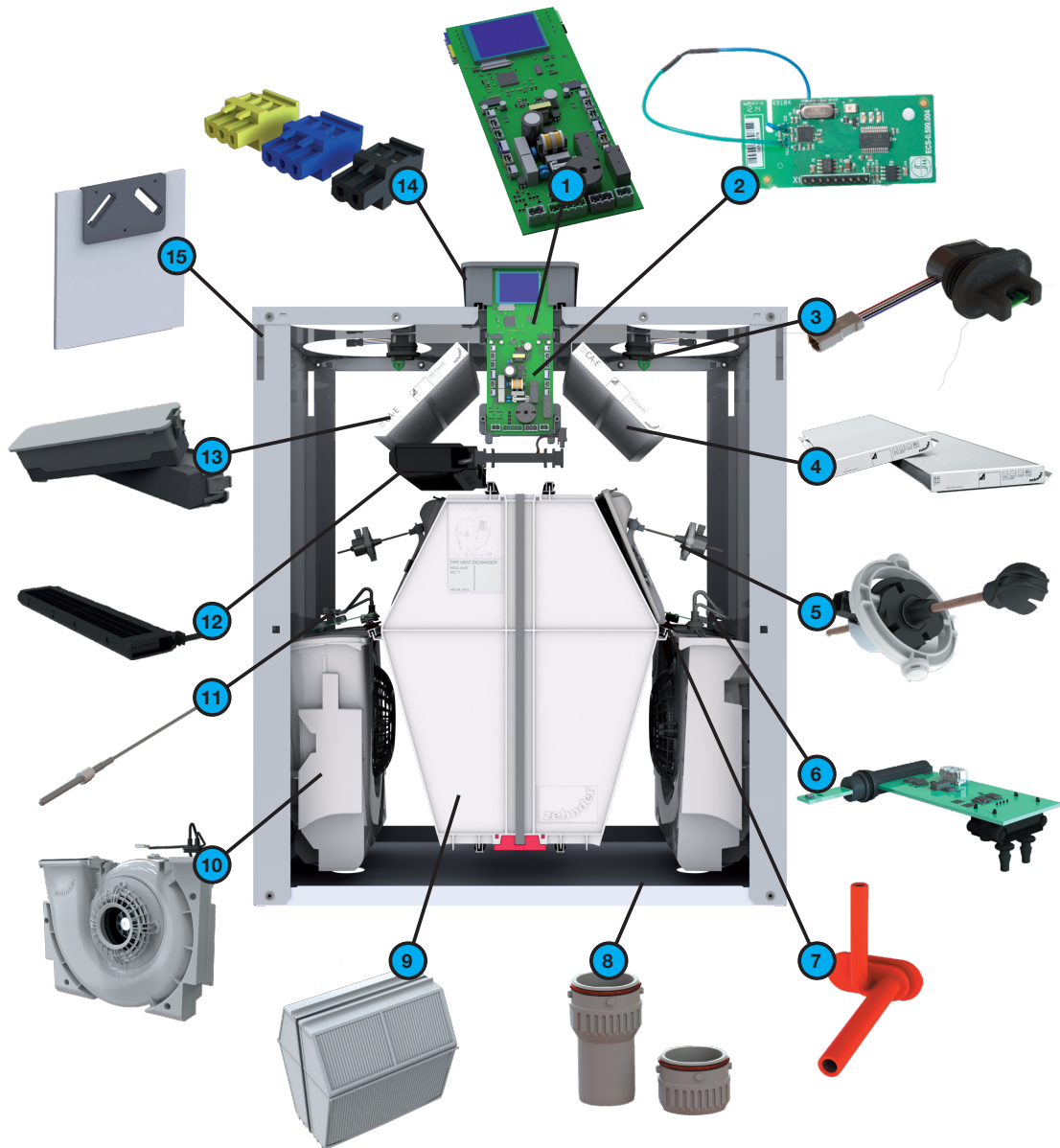

Identification	Part
1	ComfoAir E350 control PCB with display
2	RF PCB (RF receiver)
3	Sensor upper section (TEMP/RH SENSOR 11/20)
4	Filter set ISO Coarse / ISO Coarse (ISO Coarse / ISO ePM1) according to ISO 16890 (G4/G4, G4/F7)
5	Bypass motor (BYPASS MOTOR 11/20)
6	Sensor middle section (TEMP/RH SENSOR 12/22)
7	Fan pressure hose
8	Condensation drain
9	Heat exchanger
10	Fan with casing (FAN 12/22)
11	Temperature sensor T21 repair set
12	Preheater
13	Set of filter covers (2x)
14	Connector set
15	Front cover

3.2 Connection diagram

Key:

Code	Meaning
PE	Green/Yellow
N / BU	Blue
L / BK	Brown or black
WH	White
RD	Red
VT	Violet
GN	Green
YE	Yellow
GY	Grey
DISPLAY	Display
RF	RF PCB
VV	Preheater
C1	0-10 V input
C2	Bathroom switch
C3	n/a
C4	Malfunction / dirty filter alert (LED SAI Flash) Output voltage at malfunction / alert = 5 V

Meaning		
Code	Right-hand unit	Left-hand unit
B1	BYPASS MOTOR 11 extract air	BYPASS MOTOR 20 outdoor air
B11	BYPASS MOTOR 20 outdoor air	BYPASS MOTOR 11 extract air
M1	FAN 22 supply air	FAN 12 exhaust air
M11	FAN 12 exhaust air	FAN 22 supply air
S1	RH + TEMP SENSOR 11 extract air	RH + TEMP SENSOR 20 outdoor air
S11	RH + TEMP SENSOR 20 outdoor air	RH + TEMP SENSOR 11 extract air
S2	Pressure sensor 22 supply air	Pressure sensor 12 exhaust air
S22	Pressure sensor 12 exhaust air	Pressure sensor 22 supply air
S3	RH + TEMP SENSOR 22 supply air	RH + TEMP SENSOR 12 exhaust air
S33	RH + TEMP SENSOR 12 exhaust air	RH + TEMP SENSOR 22 supply air
S4	n/a	TEMP SENSOR 21 outdoor air after preheater
S44	TEMP SENSOR 21 outdoor air	n/a

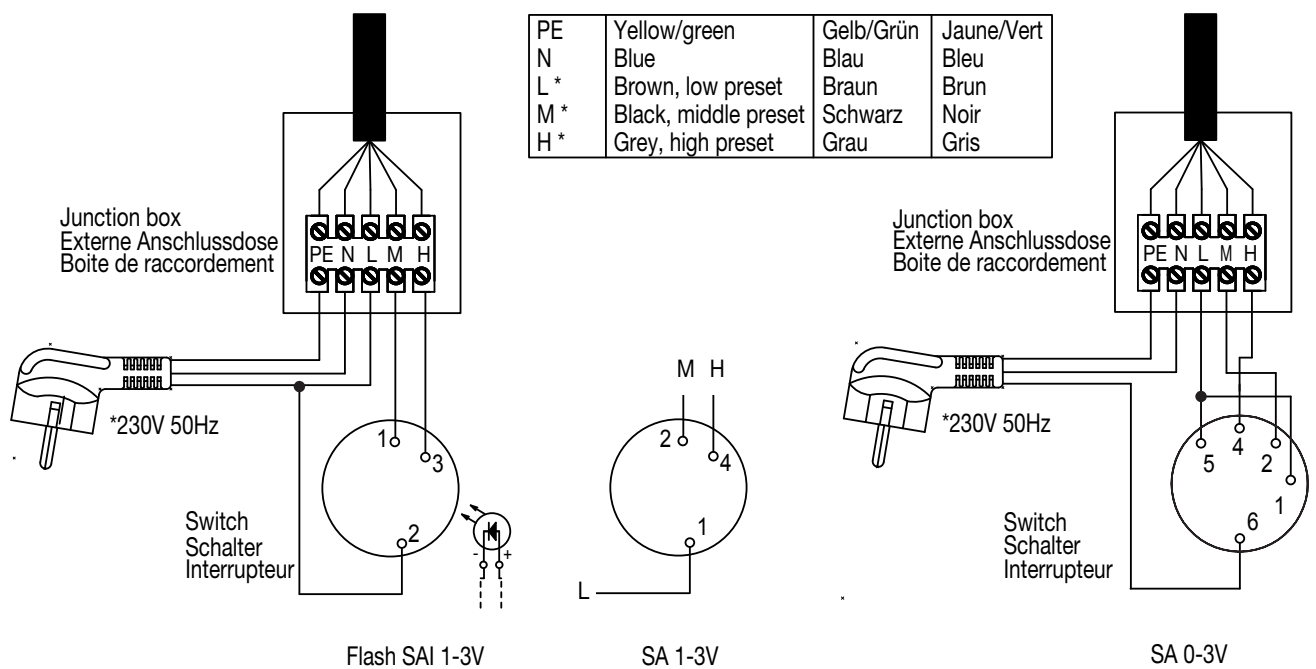

PE	Yellow/green	Gelb/Grün	Jaune/Vert
N	Blue	Blau	Bleu
L *	Brown, low preset	Braun	Brun
M *	Black, middle preset	Schwarz	Noir
H *	Grey, high preset	Grau	Gris

A control panel must always be connected to operate the unit!

Unplug the unit from the wall outlet to disconnect it from the power supply.
If the unit does not have a plug, use a switch according to EN 60335-1 (with switch-off of all poles and 3 mm overvoltage category III).

Front view of main PCB

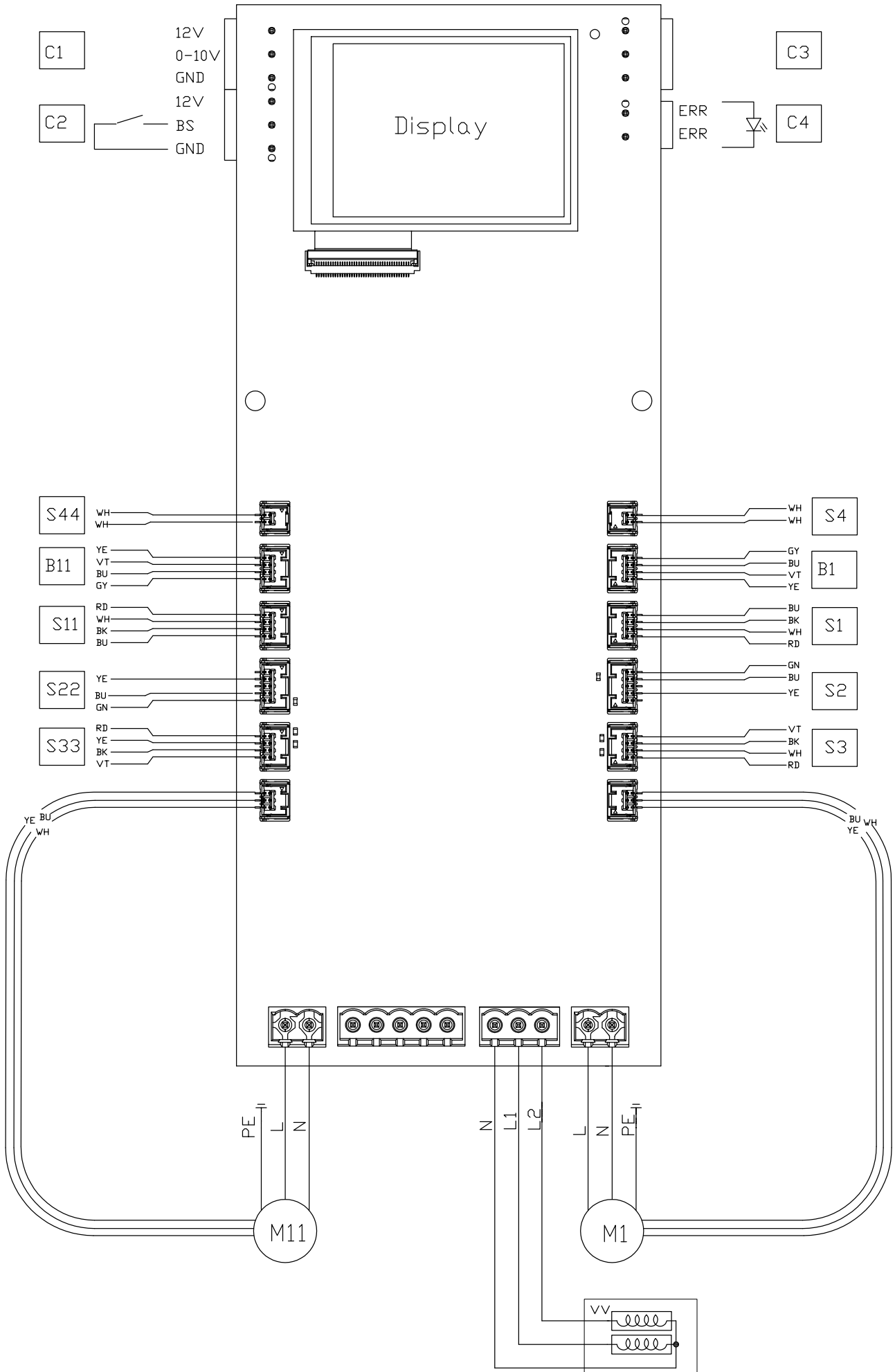

3.3 Dimension sketch

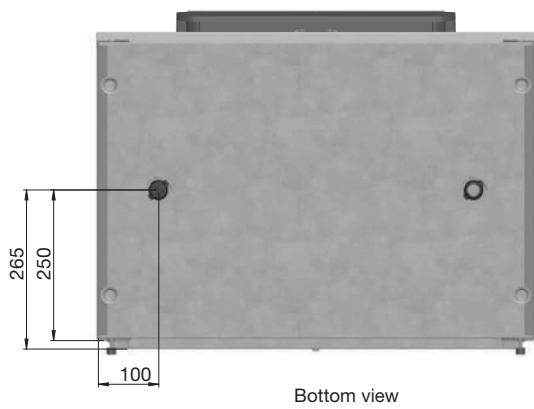
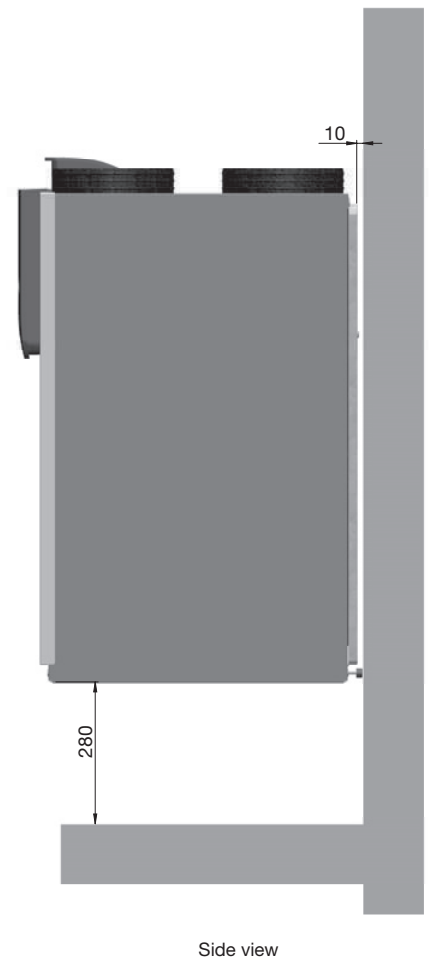
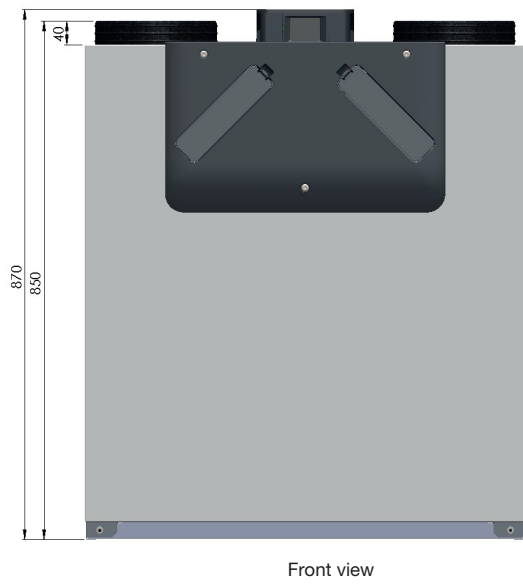
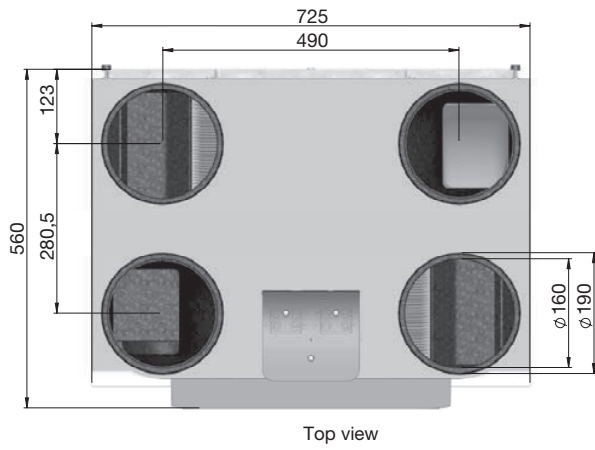

4 Maintenance procedures

 **Observe all maintenance instructions given in this section and in the user manual. If the maintenance is not performed periodically the performance of the ventilation system will ultimately be compromised.**

In the user manual you can find all the maintenance work that the user may carry out.

You can find the maintenance procedures for the accessories connected to the unit in the respective manuals. You can obtain a copy of the Zehnder manual from Zehnder.







When you need to replace a part, you can order a service part from Zehnder. In the section about service parts, you can see which service sets are available.

 **Always disconnect the power supply of the unit before you start working on the ventilation system. Operation with the casing open can lead to personal injury. In such a case, ensure that no live or rotating parts can be touched.**

 **The electronics can be damaged by static charging, so always take measures to prevent electrostatic discharge (e.g. antistatic belt) when handling the electronics.**

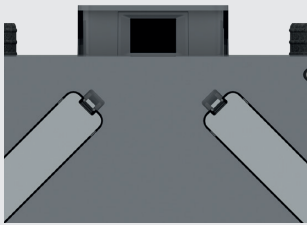
Zehnder recommends hiring a specialist cleaning company to clean the entire ventilation system

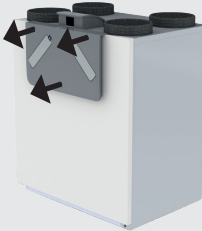
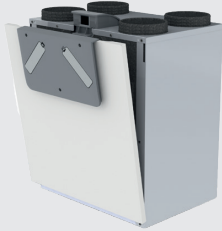

4.1 Procedure for opening the unit

	1 	2 
 Do not yet switch off the power to the unit. The current setting of the bypass valve may mean you cannot remove the heat exchanger from the unit.	Switch off the child lock on the display of the unit: ■ Press the display of the unit for about 4 seconds until the symbol  disappears.	Set the unit to SERVICE MODE. (MENU> Login> SERVICE MODE> ACTIVATE)
3 	4 	5 
Disconnect the power to the unit when the display tells you to.	Remove the 3 screws from the front cover.	Remove the front cover.

 **Unplug the unit from the wall outlet to disconnect it from the power supply. If the unit does not have a plug, use a switch according to EN 60335-1 (with switch-off of all poles and 3 mm overvoltage category III).**

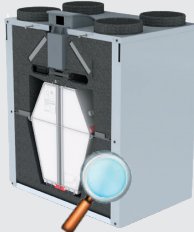

4.2 Maintenance of the casing

Check the unit casing at least once every 2 years.

<p>1</p> 	<p>2</p> 	<p>3</p> 
<p>Remove the front cover as instructed in the section on the procedure for opening the unit:</p> <ul style="list-style-type: none"> ■ Set the unit to the service mode; ■ Disconnect the power to the unit; ■ Remove the 3 screws from the front cover; ■ Remove the front cover; 	<p>Perform the following checks:</p> <ul style="list-style-type: none"> ■ Check the seals for damage; ■ Check the inside and outside for dirt and damage; ■ Check the air duct connections for dirt and damage. 	<p>Treat any signs of corrosion and other damage directly and correctly.</p> <p>! Do not treat the insulation cover and the EPP parts (black hard parts with structure) with soap. Soap will destroy the airtightness and watertightness of the material.</p>

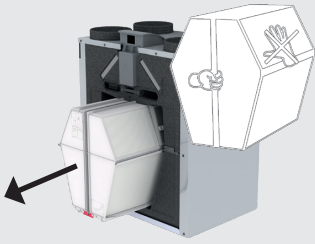

4.3 Maintenance of the heat exchanger

Inspect the heat exchanger at least once every two years.

<p>1</p> 	<p>2</p> 	<p>3</p> 
<p>Remove the front cover as instructed in the section on the procedure for opening the unit:</p> <ul style="list-style-type: none"> ■ Set the unit to the service mode; ■ Disconnect the power to the unit; ■ Remove the 3 screws from the front cover; ■ Remove the front cover. 	<p>Remove the heat exchanger:</p> <ul style="list-style-type: none"> ■ Pull on the strap of the heat exchanger. <p>! Do not cut the strap. The strap is necessary to pull out the heat exchanger from the unit.</p> <p>You can only remove the heat exchanger without damaging it when the unit is in the service mode.</p> <p>! During installation: Place the underside of the heat exchanger in the guide rails of the unit. Make sure that the red locking plate of the heat exchanger is visible on the front of the heat exchanger.</p>	<p>Check and clean the heat exchanger, if necessary</p> <ul style="list-style-type: none"> ■ Use water to remove dust and dirt: <ol style="list-style-type: none"> a. Submerge the heat exchanger a couple of times in hot water (max. 40°C). b. Rinse the heat exchanger with clean hot tap water (max. 40°C). c. Hold the heat exchanger between both hands (on the sealed side surfaces) and shake the excess water from the heat exchanger. <p>! Do not use aggressive cleaning agents or solvents. These can affect the airtightness of the heat exchanger.</p>

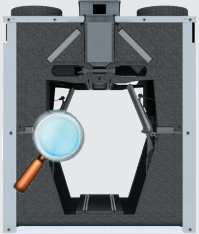

4.4 Maintenance of the bypass flaps

Inspect the bypass flaps at least once every two years.

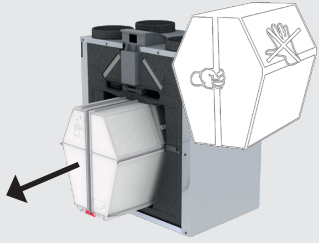
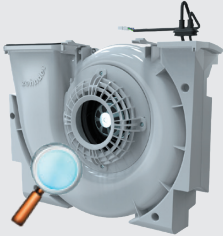

<p>1</p> 	<p>2</p> 	<p>3</p> 
<p>Remove the heat exchanger as instructed in the maintenance instructions for the heat exchanger</p> <ul style="list-style-type: none">■ Set the unit to the service mode;■ Disconnect the power to the unit;■ Remove the 3 screws from the front cover;■ Remove the front cover;■ Pull on the strap of the heat exchanger.	<p>With right-hand side appliance valve in the back: Press temperature sensor T21 up, out of the insulation cover next to the bypass flap.</p>	<p>While holding the clamp away from the flap, pull the flap towards you.</p> <p> During installation: Place the Zehnder logo at the top.</p>
<p>4</p> 	<p>5</p> 	
<p>Check the flaps of the modulating bypass for dirt and damage.</p>	<p>Treat any signs of contamination and other damage directly and correctly.</p>	<p>For the right-hand unit:</p> <ul style="list-style-type: none">■ Bypass motor 11 is to the left;■ Bypass motor 20 is to the right. <p>For the left-hand unit:</p> <ul style="list-style-type: none">■ Bypass motor 11 is to the right;■ Bypass motor 20 is to the left.

4.5 Maintenance of the fans

Check the fans at least once every two years

<p>1</p> 	<p>2</p> 	<p>3</p> 
<p>Remove the heat exchanger as instructed in the maintenance instructions for the heat exchanger:</p> <ul style="list-style-type: none"> ■ Set the unit to the service mode; ■ Disconnect the power to the unit; ■ Remove the 3 screws from the front cover; ■ Remove the front cover; ■ Pull on the strap of the heat exchanger. 	<p>Perform the following checks:</p> <ul style="list-style-type: none"> ■ Check the air grille for dirt and damage; ■ Check the casing for dirt and damage; ■ Check the fan impellers for dirt and damage; 	<p>Clean the fans and grille if necessary.</p> <ul style="list-style-type: none"> ■ Use a soft brush to clean the fan impellers; ■ Use a vacuum cleaner to remove dust. <p> Be careful not to damage the fan's impellers.</p>

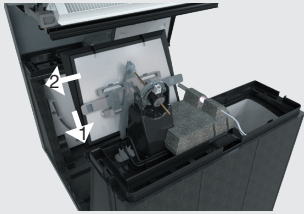
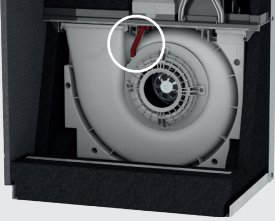
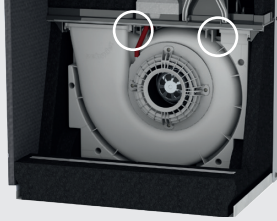
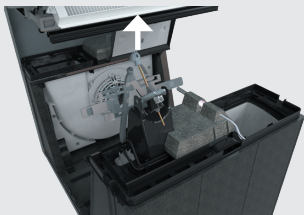
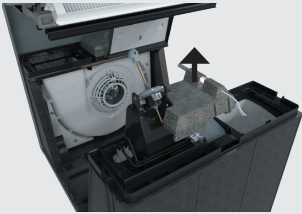

For better access to the fans, proceed as follows:

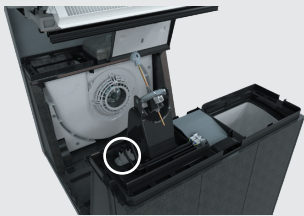
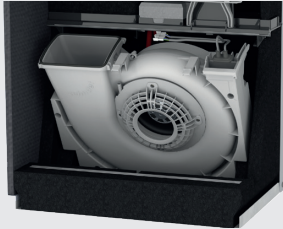
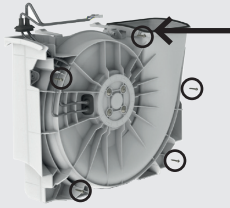
<p>1</p> 	<p>2</p> 	<p>3</p> 
<p>Remove the bypass flap according to the instructions in the corresponding section:</p> <ul style="list-style-type: none"> ■ Set the unit to the service mode; ■ Disconnect the power to the unit; ■ Remove the 3 screws from the front cover; ■ Remove the front cover; ■ Pull on the strap of the heat exchanger; ■ Valve to the rear if right-hand unit: Remove temperature sensor 21 from the insulation cover next to the bypass flap; ■ Pull the clamp to the rear of the flap away from the flap; ■ While holding the clamp away from the flap, pull the flap towards you. 	<p>Remove the two pressure hoses from the fan.</p>	<p>Press the two clamps downwards and pull the volute casing forward.</p>
<p>4</p> 	<p>5</p> 	<p>6</p> 
<p>Loosen the connection joint from the modulating bypass flap.</p>	<p>Remove the insulation cover behind the bypass flap.</p>	<p>Remove the fan connections from the sensor cover and open them.</p>

<p>7</p> 	<p>8</p> 	<p>9</p> 
<p>Remove the sealing grommet, including wiring, by pushing down the plastic bulkhead.</p>	<p>Lift the volute casing out of the unit.</p>	<p>Remove the 5 screws and the seal on the edge of the volute casing to open it.</p>

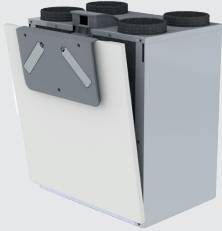
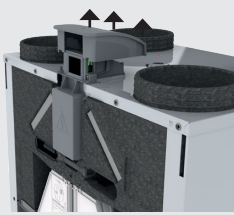
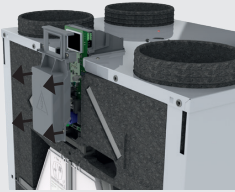
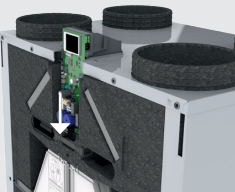
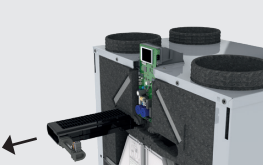

4.6 Maintenance of the preheater

Check the preheater at least once every 2 years.

<p>1</p> 	<p>2</p> 	<p>3</p> 
<p>Remove the front cover as instructed in the section on the procedure for opening the unit:</p> <ul style="list-style-type: none"> ■ Set the unit to the service mode; ■ Disconnect the power to the unit; ■ Remove the 3 screws from the front cover; ■ Remove the front cover. 	<p>Remove the 3 screws from the display cover. Then remove this cover.</p>	<p>Remove the 4 screws from the electronics cover. Then remove this cover.</p>
<p>4</p> 	<p>5</p> 	<p>6</p> 
<p>Pull the black connector of the preheater from the control PCB.</p>	<p>Remove the preheater, including wiring and sealing grommet, from the unit.</p>	<p>Check the preheater for dirt and damage</p> <p>Treat any signs of contamination and other damage directly and correctly.</p> <p>Turn the preheater upside down and:</p> <ul style="list-style-type: none"> ■ Use a soft brush to clean the fins; ■ Or use a vacuum cleaner to remove dust and dirt. <p> Do not clean the preheater with water.</p>



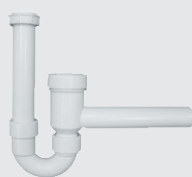

4.7 Maintenance of the condensation drain:

Check the condensation drain at least once every two years





<p>1 Example of siphon</p> 	<p>2 Example of siphon</p> 	<p>3</p> 
<p>Disconnect the condensation drain.</p>	<p>Perform the following checks on the condensation drain siphon:</p> <ul style="list-style-type: none"> ■ Check whether the drain is still open by pouring water in the siphon; ■ Visually inspect the condensation drain for contamination; ■ Check whether the seal of the condensation drain is airtight. Air may not pass along or through the siphon. 	<p>Resolve any problems detected.</p>

4.8 Maintenance of the air ducts

Check the air ducts at least once every two years

<p>1 Example valve Example grille</p> 	<p>2 Example air duct</p> 	<p>3</p> 
<p>Remove the valves.</p> <p> Zehnder recommends writing down the settings and the positions.</p>	<p>Check the air ducts for the following:</p> <ul style="list-style-type: none"> ■ Contamination (dirt and grease); ■ Air leakages (loose connections); ■ Resistance (bends, dents and blocked valves); ■ Valves. 	<p>Resolve any problems detected.</p>

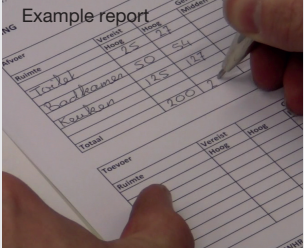
4.9 Procedure for completing maintenance

<p>1</p> 	<p>2</p> 	<p>3</p> <p>Example report</p> 
<p>Re-install parts in reverse order.</p>	<p>Reconnect the unit to the mains power.</p>	<p>Check the correct functioning of the unit through a system test (MENU> Login> SYSTEM TEST). Fill in the maintenance logbook (if present). An example of a maintenance logbook can be found in the user manual.</p>
<p> During installation:</p> <ul style="list-style-type: none"> ■ Tighten all screws hand-tight (max. 1.5 Nm); ■ Check whether the insulation cover is properly located behind the front cover. To do this, insert the middle screw through the front cover and the recess in the insulation cover. ■ Place the bottom edge of the front cover behind the raised edge of the bottom plate. This guarantees that the unit is airtight after the screws have been tightened. 		

5 Malfunction procedures

 **Always disconnect the power supply of the unit before you start working on the unit. Operation with the casing open can lead to personal injury. In such a case, ensure that no live or rotating parts can be touched.**

Only switch off the power to the unit when the instructions say so.

 **When tracing malfunctions, it is often necessary to apply voltage to the unit while the casing is open. Be aware at all times that this brings with it the risk of electrical shock and injury from rotating parts. Take all possible measures necessary to protect yourself and others while tracing a malfunction.**

 **The electronics can be damaged by static charging, so always take measures to prevent electrostatic discharge (e.g. antistatic belt) when handling the electronics.**

The unit always aims to ventilate as comfortably and healthily as possible. This is not always possible if a malfunction occurs. The unit adapts its controls during a malfunction in such a way that the unit is not damaged further, with the preference being to maintain ventilation. If the unit has more than one malfunction, the safety of the unit is not guaranteed and the ventilation will be deactivated. This also applies if the sensor in the supply air is defective. To guarantee a healthy living climate for the user, these errors must be resolved as soon as possible. The other errors will primarily impact the comfort of the user and the performance of the unit.

The section “What to do if a malfunction alert occurs (problem solving)” describes how to solve all error codes.



5.1 Malfunction alerts on the display of the unit

Code	Meaning
BYPASS MOTOR 11 ERROR	Malfunctions in the motor of the bypass valve on the extract-air side.
BYPASS MOTOR 20 ERROR	Malfunctions in the motor of the bypass valve on the outdoor-air side.
FAN 12 ERROR	Malfunctions in the fan for the exhaust air.
FAN 22 ERROR	Malfunctions in the fan for the supply air.
FILTER ALARM	Internal filters are dirty
FILTER ALERT	Increasing contamination of the internal filters  Order new filters immediately.
PRESSURE 12 ERROR	Malfunctions in the pressure sensor for the exhaust air.
PRESSURE 22 ERROR	Malfunctions in the pressure sensor for the supply air.
RH SENSOR 11 ERROR	Malfunctions in the humidity sensor for the extract air.
RH SENSOR 12 ERROR	Malfunctions in the humidity sensor for the exhaust air.
RH SENSOR 20 ERROR	Malfunctions in the humidity sensor for the outdoor air.
RH SENSOR 22 ERROR	Malfunctions in the humidity sensor for the supply air.
TEMP SENSOR 11 ERROR	Malfunctions in the temperature sensor for the extract air.
TEMP SENSOR 12 ERROR	Malfunctions in the temperature sensor for the exhaust air.
TEMP SENSOR 20 ERROR	Malfunctions in the temperature sensor for the outdoor air upstream of the preheater.
TEMP SENSOR 21 ERROR	Malfunctions in the temperature sensor for the outdoor air downstream of the preheater.
TEMP SENSOR 22 ERROR	Malfunctions in the temperature sensor for the supply air.
PREHEAT. ERROR	The preheater does not heat sufficiently.
PREHEAT. TOO HOT	The preheater is getting too hot.
PREHEAT. LOC. ERROR	The preheater is not at the correct location, is defective or absent.

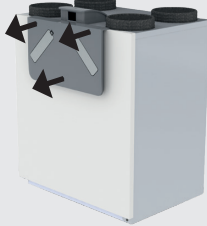
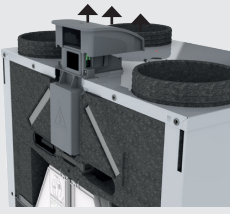
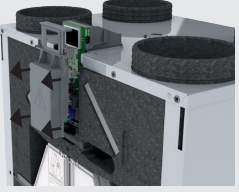
5.2 Access to the control PCB

<p>1</p> 	<p>2</p> 	<p>3</p> 
<p>Disconnect the power to the unit. Remove the 3 screws from the front cover. Then remove this cover.</p>	<p>Remove the 3 screws from the display cover. Then remove this cover.</p>	<p>Remove the 4 screws from the electronics cover. Then remove this cover.</p>

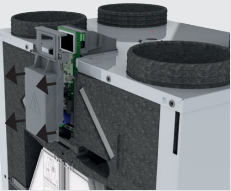
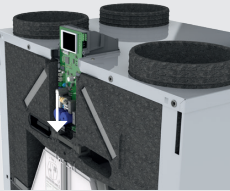
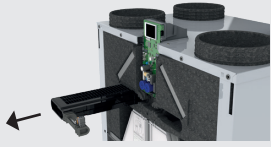
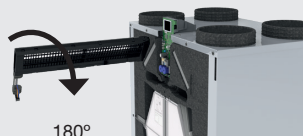
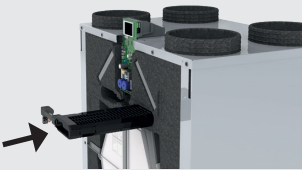
5.3 Changing the installation position of the preheater

<p>1</p> 	<p>2</p> 	<p>3</p> 
<p>Go to the control PCB as described in Section 'Access to the control PCB':</p> <ul style="list-style-type: none"> ■ Disconnect the power to the unit. ■ Remove the 3 front cover screws. ■ Remove the 3 screws from the display cover. Then remove the cover; ■ Remove the 4 screws from the electronics cover. Then remove the cover. 	<p>Pull the black connector of the preheater from the control PCB.</p>	<p>Remove the preheater, including wiring and sealing grommet, from the unit.</p>
<p>4</p> 	<p>5</p> 	
<p>Rotate the preheater 180°.</p>	<p>Slide the preheater, including wiring and sealing grommet, to the other side in the unit.</p>	<p>For the right-hand unit: The preheater is located on the left.</p> <p>For the left-hand unit: The preheater is located on the right.</p>

5.4 Access to the T11/T20 sensor

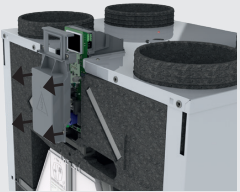
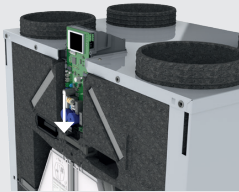
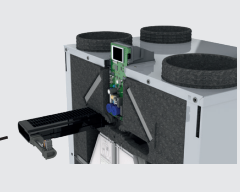
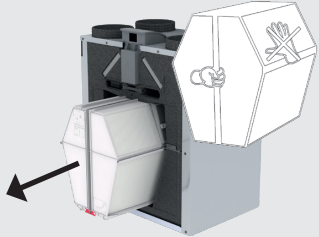
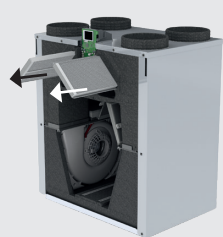
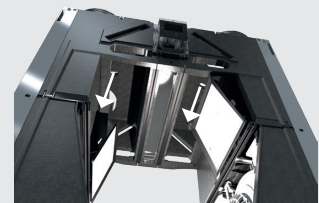
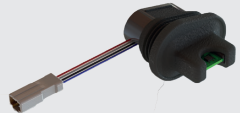
<p>1</p> 	<p>2</p> 	<p>3</p> 
<p>Go to the control PCB as described in the section "Access to the control PCB":</p> <ul style="list-style-type: none"> ■ Disconnect the power to the unit. ■ Remove the 3 front cover screws. ■ Remove the 3 screws from the display cover. Then remove the cover; ■ Remove the 4 screws from the electronics cover. Then remove the cover. 	<p>Pull the black connector of the preheater from the control PCB.</p>	<p>Remove the preheater, including wiring and sealing grommet, from the unit.</p> <p>For the right-hand unit: The preheater is located on the left.</p> <p>For the left-hand unit: The preheater is located on the right.</p>
<p>4</p> 	<p>5</p> 	<p>6</p> 
<p>Remove the heat exchanger:</p> <ul style="list-style-type: none"> ■ Pull on the strap of the heat exchanger. <p>! Do not cut the strap. The strap is necessary to pull out the heat exchanger from the unit.</p> <p>You can only remove the heat exchanger when the unit is in the service mode.</p> <p>👉 During installation: Place the underside of the heat exchanger in the guide rails of the unit. Make sure that the red bottom plate sits at the front of the appliance.</p>	<p>Remove the filters.</p>	<p>Pull the sensor down from the inside of the unit. Then remove the connector from the sensor.</p>  <p>For the right-hand unit:</p> <ul style="list-style-type: none"> ■ T11 is to the right; ■ T20 is to the left. <p>For the left-hand unit:</p> <ul style="list-style-type: none"> ■ T11 is to the left; ■ T20 is to the right.

5.5 Access to the T12/T21/T22 sensor

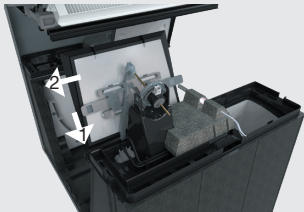
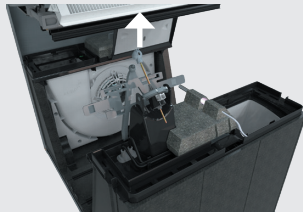
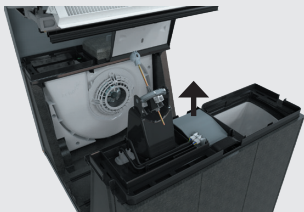
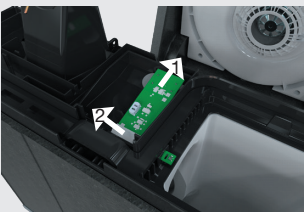
		
<p>Remove the bypass flap as instructed in the relevant section:</p> <ul style="list-style-type: none">■ Set the unit to the service mode;■ Disconnect the power to the unit;■ Remove the 3 screws from the front cover;■ Remove the front cover;■ Pull on the strap of the heat exchanger.■ If T21 present: Press temperature sensor T21 upwards, out of the insulation cover next to the bypass flap;■ Pull the clamp to the rear of the flap away from the flap;■ While holding the clamp away from the flap, pull the flap towards you.	<p>Loosen the connection joint from the bypass flap.</p>	<p>Remove the insulation cover behind the bypass flap.</p>
		
<p>Remove the fan connectors of the sensor cover. Remove the sensor cover by opening the snap connector.</p>	<p>Remove the connector for the sensor.</p> 	<p>Pull the sensor upwards from the rubber holder for the pressure sensor. Then pull the sensor sideways from the sensor container.</p>

5.6 Resetting errors

Most errors will automatically reset themselves once the problem has been resolved.

The following errors can only be reset by a SYSTEM TEST of the unit:

- BYPASS MOTOR 11 ERROR;
- BYPASS MOTOR 20 ERROR;
- PREHEAT. ERROR;
- PREHEAT. TOO HOT;
- PREHEAT. LOC. ERROR.

The filter errors can only be reset in the filter-replacement menu of the user.

5.7 Carrying out a system test

It is recommended to run system tests regularly because some errors are only detected during a system test (e.g. bypass errors). The system test takes about 5-10 minutes. Ensure that during the system test, the unit has a heat exchanger and that the casing is closed (front cover fitted). In addition, the HIGH SETTING must be set to a minimum of 160 m³/h and 150 m³/h must be possible in the ventilation system. If that is not the case, the system test will not be completed without errors.

5.8 What to do if a malfunction alert occurs (problem solving)

Error code BYPASS MOTOR 11 ERROR / BYPASS MOTOR 20 ERROR		Malfunctions in the motor of the bypass valve on the extract-air / outdoor-air side. ■ For the right-hand unit: BYPASS MOTOR 11 is to the right; ■ For the left-hand unit: BYPASS MOTOR 11 is to the left.	
Question	Answer	Action	
1	Is the front of the unit closed (front cover fitted)?	Yes	1. Remove and inspect the bypass valves and motors as described in the section "Maintenance of the bypass valves". 2. Go to the next question.
		No	Follow the procedure for completing the maintenance.
2	Are the bypass valves and motors clean?	Yes	1. Ensure that the heat exchanger is in the unit. 2. Switch on the power to the unit. ⚠ Make sure that no-one touches rotating parts or parts under live power. 3. Inspect the bypass valves during startup. 4. Go to the next question.
		No	1. Clean the bypass valves and motors. 2. Follow the procedure for completing the maintenance.
3	Do the bypass valves move?	Yes	1. Get the service set for the control PCB. 2. Replace the control PCB as described in the manual supplied. 3. Follow the procedure for completing the maintenance.
		No	1. Get the service set for the bypass motor. 2. Replace the bypass motor as described in the manual supplied. 3. Follow the procedure for completing the maintenance.

Error code FAN 12 ERROR / FAN 22 ERROR		Malfunctions in the fan for the exhaust air / supply air. ■ For the right-hand unit: FAN 12 is to the right; ■ For the left-hand unit: FAN 12 is to the left.	
Question	Answer	Action	
1	n/a	n/a	1. Remove the electronics cap as described in the section "Access to the control PCB". 2. Go to the next question.
2	Are all connectors properly connected to the control PCB? (See connection diagram in the Section "Technical specifications")	Yes	1. Inspect the fans as described in the maintenance Section "Maintenance of the fans". 2. Go to the next question.
		No	1. Connect everything as described in the connection diagram in Section "Technical specifications". 2. Follow the procedure for completing the maintenance.
3	Are the fan connectors in the T12/T22 sensor cover properly connected?	Yes	1. Ensure that the heat exchanger is in the unit. 2. Place a voltmeter over the power connector of the fan (AC: black – blue) 3. Switch on the power to the unit. ⚠ Make sure that no-one touches rotating parts or parts under live power. 4. Go to the next question.
		No	1. Connect the fan connectors properly. 2. Follow the procedure for completing the maintenance.
4	If there a voltage of about 230 V on the power connector?	Yes	1. Get the service set for the fan. 2. Replace the fan as described in the manual supplied. 3. Go to the next question.
		No	1. Get the service set for the control PCB. 2. Replace the control PCB as described in the manual supplied. 3. Follow the procedure for completing the maintenance.
5	Did the error alert return?	Yes	1. Get the service set for the control PCB. 2. Replace the control PCB as described in the manual supplied. 3. Follow the procedure for completing the maintenance.

Error code FILTER ALARM	Internal filters are dirty, you must replace the internal filters.
Action	
Replace the filters directly as described in the user manual.	

FILTER WARNING	Internal filters are almost dirty, you must replace the internal filters soon.
Action	
1. Order new filters. 2. Replace the filters as described in the user manual.	

Error code PRESSURE 12 ERROR / PRESSURE 22 ERROR		Malfunction in the pressure sensor for the exhaust air / supply air. ■ For the right-hand unit: PRESSURE SENSOR 22 is to the right; ■ For the left-hand unit: PRESSURE SENSOR 22 is to the centre-left;	
Question	Answer	Action	
1	n/a	n/a	
2	Are all connectors properly connected to the control PCB? (See connection diagram in the section "Technical specifications")	Yes	1. Check the connector of the sensor. How to get access to the sensor can be found in the section "Access to the T12/T21/T22 sensor". 2. Go to the next question.
	No	1. Connect everything as described in the connection diagram in the section "Technical specifications". 2. Follow the procedure for completing the maintenance.	
3	Is the connector properly connected to the sensor?	Yes	1. Get the service set for the sensor of the central section. 2. Replace the sensor as described in the manual supplied. 3. Go to the next question.
	No	1. Connect the connector properly. 2. Follow the procedure for completing the maintenance.	
4	Did the error alert return?	Yes	1. Get the service set for the control PCB. 2. Replace the control PCB as described in the manual supplied. 3. Follow the procedure for completing the maintenance.
Error code RH SENSOR 11 ERROR / RH SENSOR 20 ERROR		Malfunctions in the humidity sensor for the extract air / outdoor air. ■ For the right-hand unit: RH SENSOR 11 is to the top-right of the unit; ■ For the left-hand unit: RH SENSOR 11 is to the top-left of the unit.	
Question	Answer	Action	
1	n/a	n/a	
2	Are all connectors properly connected to the control PCB? (See connection diagram in the section "Technical specifications")	Yes	1. Check the connector of the sensor. How to get access to the sensor can be found in the malfunction Section "Access to the T11/T20 sensor". 2. Go to the next question.
	No	1. Connect everything as described in the connection diagram in the section "Technical specifications". 2. Follow the procedure for completing the maintenance.	
3	Is the connector properly connected to the sensor?	Yes	1. Get the service set for the sensor of the upper section. 2. Replace the sensor as described in the manual supplied. 3. Go to the next question.
	No	1. Connect the connector properly. 2. Follow the procedure for completing the maintenance.	
4	Did the error alert return?	Yes	1. Get the service set for the control PCB. 2. Replace the control PCB as described in the manual supplied. 3. Follow the procedure for completing the maintenance.
Error code RH SENSOR 12 ERROR / RH SENSOR 22 ERROR /		Malfunctions in the humidity sensor for the exhaust air / outdoor air. ■ For the right-hand unit: RH SENSOR 22 is to the centre-right of the unit; ■ For the left-hand unit: RH SENSOR 22 is to the centre-left of the unit.	
Question	Answer	Action	
1	n/a	n/a	
2	Are all connectors properly connected to the control PCB? (See connection diagram in the section "Technical specifications")	Yes	1. Check the connector of the sensor. How to get access to the sensor can be found in the section "Access to the T12/T21/T22 sensor". 2. Go to the next question.
	No	1. Connect everything as described in the connection diagram in the section "Technical specifications". 2. Follow the procedure for completing the maintenance.	
3	Is the connector properly connected to the sensor?	Yes	1. Get the service set for the sensor of the central section. 2. Replace the sensor as described in the manual supplied. 3. Go to the next question.
	No	1. Connect the connector properly. 2. Follow the procedure for completing the maintenance.	
4	Did the error alert return?	Yes	1. Get the service set for the control PCB. 2. Replace the control PCB as described in the manual supplied. 3. Follow the procedure for completing the maintenance.

Error code TEMP SENSOR 11 ERROR / TEMP SENSOR 20 ERROR		Malfunctions in the temperature sensor for the extract air / outdoor air upstream of the preheater. ■ For the right-hand unit: TEMP SENSOR 11 is to the top-right of the unit; ■ For the left-hand unit: TEMP SENSOR 11 is to the top-left of the unit.	
Question	Answer	Action	
1	Is the air temperature in the unit outside of the range > -40°C to < 70°C? (Less than -40°C or greater than 70°C)	Yes	Ensure that the temperature in the unit returns to within the temperature range of the sensor: 1. If the outdoor temperature is within the temperature range: Set the unit for some time to ventilation setting 3 to quickly return the temperature in the unit to within the temperature range. 2. Once the temperature in the unit is within the temperature range: Inspect the heat exchanger as described in the section "Maintenance of the heat exchanger". 3. Go to the next question.
	No	1. Inspect the heat exchanger as described in the section "Maintenance of the heat exchanger". 2. Go to the next question.	
2	Is the error alert still displayed?	Yes	1. Switch off the power to the unit. 2. Remove the electronics cap as described in the section "Access to the control PCB".
3	Are all connectors properly connected to the control PCB? (See connection diagram in the section "Technical specifications")	Yes	1. Check the connector of the sensor. How to get access to the sensor can be found in the malfunction Section "Access to the T11/T20 sensor". 2. Go to the next question.
	No	1. Connect everything as described in the connection diagram in the section "Technical specifications". 2. Follow the procedure for completing the maintenance.	
4	Is the connector properly connected to the sensor?	Yes	1. Get the service set for the sensor of the upper section. 2. Replace the sensor as described in the manual supplied. 3. Go to the next question.
	No	1. Connect the connector properly. 2. Follow the procedure for completing the maintenance.	
5	Did the error alert return?	Yes	1. Get the service set for the control PCB. 2. Replace the control PCB as described in the manual supplied. 3. Follow the procedure for completing the maintenance.
Error code TEMP SENSOR 12 ERROR / TEMP SENSOR 21 ERROR / TEMP SENSOR 22 ERROR /		Malfunctions in the temperature sensor for the exhaust air / outdoor air downstream of the preheater. ■ For the right-hand unit: TEMP SENSOR 12 and 21 are to the centre-left of the unit; ■ For the left-hand unit: TEMP SENSOR 12 and 21 are to the centre-right of the unit.	
Question	Answer	Action	
1	Is the air temperature in the unit outside of the range > -40°C to < +70°C? (Less than -40°C or greater than +70°C)	Yes	1. Ensure that the temperature in the unit returns to within the temperature range of the sensor: If the outdoor temperature is within the temperature range: Set the unit for some time to ventilation setting 3 to quickly return the temperature in the unit to within the temperature range. 2. Once the temperature in the unit is within the temperature range: Inspect the heat exchanger as described in the section "Maintenance of the heat exchanger". 3. Go to the next question.
	No	1. Inspect the heat exchanger as described in the section "Maintenance of the heat exchanger". 2. Go to the next question.	
2	Is the error alert still displayed?	Yes	1. Switch off the power to the unit. 2. Remove the electronics cap as described in the section "Access to the control PCB".
3	Are all connectors properly connected to the control PCB? (See connection diagram in the section "Technical specifications")	Yes	If TEMP SENSOR 21 ERROR: 1. Get the service set for temperature sensor T21. 2. Replace the sensor as described in the manual supplied. 3. Go to the last question. If TEMP SENSOR 12 ERROR or TEMP SENSOR 22 ERROR: 1. Check the connector of the sensor. How to get access to the sensor can be found in the section "Access to the T12/T21/T22 sensor". 2. Go to the next question.
	No	1. Connect everything as described in the connection diagram in the section "Technical specifications". 2. Follow the procedure for completing the maintenance.	
4	Is the connector properly connected to the sensor?	Yes	1. Get the service set for the sensor of the central section. 2. Replace the sensor as described in the manual supplied. 3. Go to the next question.
	No	1. Connect the connector properly. 2. Follow the procedure for completing the maintenance.	
5	Did the error alert return?	Yes	1. Get the service set for the control PCB. 2. Replace the control PCB as described in the manual supplied. 3. Follow the procedure for completing the maintenance.

Error code PREHEAT. ERROR		The preheater does not heat sufficiently. ■ For the right-hand unit: PREHEATER and T21 are to the left; ■ For the left-hand unit: PREHEATER and T21 are to the right.	
Question	Answer	Action	
1	n/a	n/a	
2	Is the resistance of temperature sensor T21 correct? (See Section "Technical specifications")	Yes	1. Disconnect the preheater plug from the control PCB. 2. Place a resistance meter over the connector of the preheater (blue-brown and blue-black). 3. Go to the next question.
	No	1. Get the service set for temperature sensor T21. 2. Replace temperature sensor T21 as described in the manual supplied.	
3	Does the preheater give an infinite resistance?	Yes	1. Get the service set for the preheater. 2. Replace the preheater as described in the manual supplied. 3. Follow the procedure for completing the maintenance.
	No	Go to the next question.	
4	Is the resistance less than 10 Ohm?	Yes	1. Get the service set for the preheater. 2. Replace the preheater as described in the manual supplied. 3. Get the service set for the control PCB. 4. Replace the control PCB as described in the manual supplied. 5. Follow the procedure for completing the maintenance.
	No	1. Get the service set for the control PCB. 2. Replace the control PCB as described in the manual supplied. 3. Follow the procedure for completing the maintenance.	

Error code PREHEAT. TOO HOT		The preheater is getting too hot. ■ For the right-hand unit: PREHEATER is to the left; ■ For the left-hand unit: PREHEATER is to the right.	
Question	Answer	Action	
1	Is temperature sensor T21 replaced with a sensor that is not supplied by the manufacturer?	Yes	1. Get the service set for temperature sensor T21. 2. Replace temperature sensor T21 as described in the manual supplied. 3. Follow the procedure for completing the maintenance.
	No	1. Inspect the heat exchanger as described in the section "Maintenance of the heat exchanger". 2. Get the service set for the control PCB. 3. Replace the control PCB as described in the manual supplied. 4. Follow the procedure for completing the maintenance.	
2	Does the error alert return once the preheater is operated?	Yes	1. Inspect the heat exchanger as described in the section "Maintenance of the heat exchanger". 2. Get the service set for the control PCB. 3. Replace the control PCB as described in the manual supplied. 4. Follow the procedure for completing the maintenance.

Error code PREHEAT. LOC. ERROR		The preheater is not at the correct location, is defective or absent. ■ For the right-hand unit: PREHEATER and T21 are to the left; ■ For the left-hand unit: PREHEATER and T21 are to the right.	
Question	Answer	Action	
1	Is the front of the unit closed (front cover fitted)?	Yes	Go to the next question.
		No	Follow the procedure for completing the maintenance.
2	Is there a FAN 22 ERROR or TEMP SENSOR 21 ERROR?	Yes	Solve the error as per the relevant resolution table.
		No	1. Open the designer front as described in the step 1 of the malfunction Section "Access to the control PCB". 2. Go to the next question.
3	Is the preheater located on the correct side?	Yes	Go to the next question.
		No	1. Change the location of the preheater as described in the malfunction Section "Change the location of the preheater". 2. Follow the procedure for completing the maintenance.
4	Is the separator of temperature sensor T21 clicked into the insulation cover?	Yes	1. Remove the electronics cap as described in the section "Access to the control PCB". 2. Go to the next question.
		No	1. Place temperature sensor T21 properly in the insulation cover beside the bypass valve. How to get access to this sensor can be found in the maintenance Section "Maintenance of the bypass valves". 2. Follow the procedure for completing the maintenance.
5	Are all connectors properly connected to the control PCB? (See connection diagram in the section "Technical specifications")	Yes	1. Place a resistance meter over the connector of the preheater (blue – brown, and blue – black). 2. Go to the next question.
		No	1. Connect everything as described in the connection diagram in the section "Technical specifications". 2. Follow the procedure for completing the maintenance.
6	Does the preheater give an infinite resistance?	Yes	1. Get the service set for the preheater. 2. Replace the preheater as described in the manual supplied. 3. Follow the procedure for completing the maintenance.
		No	1. Get the service set for the control PCB. 2. Replace the control PCB as described in the manual supplied. 3. Follow the procedure for completing the maintenance.

5.9 What to do if a malfunction (or problem) occurs without error alert (problem solving)

Problem:		The display and the fan of the unit are not activated (the unit does not switch on).	
Question	Answer	Action	
1	Are the fuses in the meter cupboard engaged?	Yes	Go to the next question.
		No	Engage the fuses in the meter cupboard.
2	Is there power in the rest of the dwelling?	Yes	1. Check the mains cable. 2. Go to the next question.
		No	Call your energy supplier to report a power outage.
3	Is the mains cable damaged?	Yes	Replace the cable.
		No	Go to the next question.
4	Is the mains cable connected to the wall socket?	Yes	1. Remove the electronics cap as described in the section "Access to the control PCB". 2. Go to the next question.
		No	Insert the plug into the wall socket.
5	Are all connectors properly connected to the control PCB? (See connection diagram in the section "Technical specifications")	Yes	1. Get the service set for the control PCB. 2. Replace the control PCB as described in the manual supplied.
		No	1. Connect everything as described in the connection diagram in the section "Technical specifications". 2. Follow the procedure for completing the maintenance.

Problem:		There is too much noise.	
Question	Answer	Action	
1	n/a	n/a	Carry out the system test of the unit as described in the section "Carrying out a system test".
2	Does the unit have an error?	Yes	Solve the error as described in the relevant malfunction table.
		No	Go to the next question.
3	Does the unit make a whistling noise?	Yes	Find the air opening and seal it.
		No	Go to the next question.
4	Does the unit make a guzzling noise?	Yes	1. Inspect the condensation drain as described in the maintenance Section "Maintenance of the condensation drain". 2. Follow the procedure for completing the maintenance.
		No	Go to the next question.
5	Does the unit make a noise that sounds like air escaping?	Yes	1. Check the filters 2. Go to the next question.
		No	1. Open the fans as described in the maintenance Section "Maintenance of the fans". 2. Go to question 6.
6	Is there something wrong with the filters?	Yes	Solve the problem detected.
		No	1. Check the valves. 2. Go to the next question.
7	Connect the valves properly to the air ducts?	Yes	1. Set the valves using a flow meter to the correct airflow rate for each room. 2. Inform the residents that it is important to not change the settings of the valves.
		No	Re-install the valves.
8	Are the bearings of the fan damaged?	Yes	1. Get the service set for the fan. 2. Replace the fan as described in the manual supplied.
		No	1. Follow the procedure for completing the maintenance. 2. Set the pre-set airflow rate lower.

Problem:		There is water leakage (condensation).	
Question	Answer	Action	
1	Do the air ducts have vapour-proof insulation	Yes	Go to the next question.
		No	Fit vapour-proof insulation to the air ducts.
2	Is the condensation water running from the exhaust-air duct into the unit?	Yes	Go to the next question.
		No	Connect the exhaust-air duct correctly.
3	Is the condensation drain correctly connected?	Yes	1. Clean the condensation drain as described in the Section "Maintenance of the condensation drain". 2. Follow the procedure for completing the maintenance.
		No	1. Connect the condensation drain correctly. 2. Follow the procedure for completing the maintenance.

 **Condensation may form on the outside of the unit if the unit is fitted in a location with a higher-than-average ambient humidity. This is comparable to condensation on a window. The unit is not designed for these conditions.**

Problem:		The temperature of the supply air is high in summer.	
Question	Answer	Action	
1	Is an error shown on the display?	Yes	Solve the error as per the relevant resolution table.
		No	1. Carry out a system test. Go to (MENU> Login> SYSTEM TEST). If this menu is not available, switch the unit off and on again. 2. Go to the next question.
2	Is there a BYPASS MOTOR 11 ERROR or BYPASS MOTOR 20 ERROR?	Yes	Solve the error as per the relevant resolution table.
		No	Go to the next question.
3	Has it been cold for an extended period?	Yes	The unit thinks that it is winter. a. Wait until the unit thinks that it is summer. This happens automatically if it remains hot for a longer period. b. Reset the RMOT (average temperature of the outdoor air over 5 days). Do this by temporarily switching off the power to the unit.
		No	Lower the comfort temperature as described in the user manual.

Problem:		The temperature of the supply air is low in winter.	
Question	Answer	Action	
1	n/a	n/a	1. Carry out a system test. Go to (MENU> Login> SYSTEM TEST). If this menu is not available, switch the unit off and on again. 2. Go to the next question.
2	Is there a BYPASS MOTOR 11 ERROR, BYPASS MOTOR 20 ERROR, PREHEAT. TOO HOT or PREHEAT. ERROR?	Yes	Solve the error as per the relevant resolution table.
		No	Go to the next question.
3	Has it been hot for an extended period?	Yes	The unit thinks that it is summer. a. Wait until the unit thinks that it is winter. This happens automatically if it remains cold for a longer period. b. Reset the RMOT (average temperature of the outdoor air over 5 days). Do this by temporarily switching off the power to the unit.
		No	Raise the comfort temperature as described in the user manual.

Problem: The non-wireless controls are not working as expected.			
Question	Answer	Action	
1	Is the bathroom control active? (Active = bathroom switch on or recently on in last half hour)	Yes	1. If bathroom switch still on: Turn the bathroom switch off. 2. Wait until the timer of the bathroom control has finished. This takes no more than half an hour.
		No	Go to the next question.
2	Are the settings of the analogue input programmed as per the specifications of the controls? (See the manual for the controls for the correct specifications.)	Yes	Go to the next question.
		No	Set the ANALOGUE 0-10 V menus as per the specifications of the controls.
3	Are the connections of the switch correct? (See the manual for the controls for the correct connection details.)	Yes	1. Order a new switch. 2. Replace the switch as described in the manual supplied. 3. Go to the next question.
		No	Reconnect the switch.
4	Does the switch still not work?	Yes	1. Get the service set for the control PCB. 2. Replace the control PCB as described in the manual supplied.

Problem: RF controls not working as expected.			
Question	Answer	Action	
1	Is the bathroom control active? (Active = bathroom switch on or recently on in last half hour)	Yes	1. If bathroom switch still on: Turn the bathroom switch off. 2. Wait until the timer of the bathroom control has finished. This takes no more than half an hour.
		No	Go to the next question.
2	Are the settings of the RF input programmed as per the specifications of the controls? (See the manual for the controls for the correct specifications.)	Yes	Go to the next question.
		No	Set the RF SETTING menus as per the specifications of the controls.
3	Is the battery empty (if present)?	Yes	1. Buy a suitable new battery. 2. Replace the battery as described in the manual for the controls.
		No	Go to the next question.
4	Are the RF controls correctly programmed to the unit?	Yes	Go to the next question.
		No	Programme the RF controls to the unit as described in the Section "Programming the RF controls".
5	Does the switch still not work?	Yes	1. Remove the electronics cap as described in the section "Access to the control PCB". 2. Remove the control PCB. 3. Check whether the RF PCB is properly connected to the control PCB. 4. Go to the next question.
6	Is the RF PCB properly connected to the control PCB?	Yes	1. Get the service set for the RF PCB. 2. Replace the RF PCB as described in the manual supplied. 3. Go to the next question.
		No	1. Connect the RF PCB properly to the control PCB. 2. Follow the procedure for completing the maintenance. 3. Go to the next question.
7	Does the switch still not work?	Yes	1. Get the service set for the control PCB. 2. Replace the control PCB as described in the manual supplied.





