

ComfoAir 200

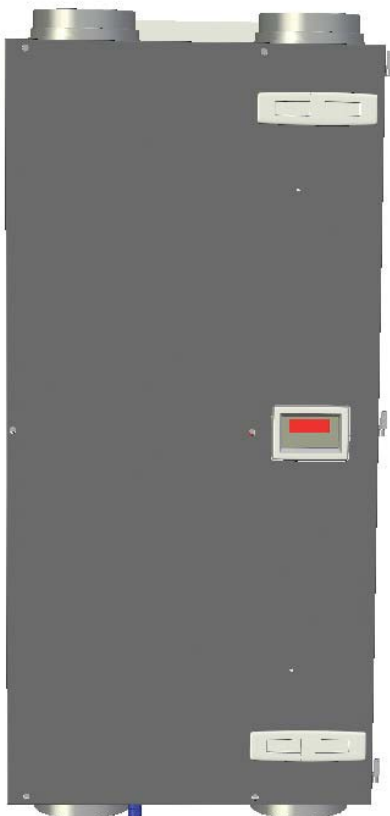

Manual

All rights reserved.

This manual has been compiled with the utmost care. The publisher cannot be held liable for any damage caused as a result of missing or incorrect information in this manual.

Table of Contents

1	INTRODUCTION	1
1.1	Preface	1
1.2	CE marking	1
1.3	Guarantee and liability	1
1.3.1	General	1
1.3.2	Guarantee conditions	1
1.3.3	Liability	1
1.4	Safety	2
1.4.1	Safety regulations	2
1.4.2	Safety provisions and measures	2
1.4.3	Pictograms used	2
2	FOR THE USER	3
2.1	Glossary	3
2.1.1	Balanced ventilation	3
2.1.2	Heat recovery	3
2.1.3	Bypass for free cooling	3
2.1.4	Frost protection	3
2.1.5	Chimney sweep programme	3
2.1.6	0-10 V input	3
2.1.7	Frost-free element (optional)	3
2.1.8	Enthalpy (optional)	3
2.2	Available operating devices	4
2.2.1	Display	4
2.2.2	3-position switch	4
2.2.3	CO ₂ sensor	5
2.2.4	Bathroom switch	5
2.2.5	CC Ease panel	5
2.3	Operating the CC Ease panel	6
2.3.1	Setting the date and time	6
2.3.2	Reading and setting the comfort temperature	7
2.3.3	Reading and setting the ventilation volume	7
2.3.4	Switching temporary High on	8
2.3.5	Switching the supply and exhaust fan on/off	8
2.3.6	Setting the ventilation programme	8
2.3.7	Setting additional programmes	9
2.4	Maintenance by the user	12
2.4.1	Cleaning or replacing the filters	12
2.4.2	Cleaning the valves (in your dwelling)	13

2.5	Malfunctions	13
2.5.1	Malfunction alerts on digital operating devices	13
2.5.2	3-position switches with malfunction indicator	14
2.5.3	What to do in the event of a malfunction	14
2.6	End of useful life	14
3.	FOR THE INSTALLER	15
3.1	ComfoAir 200	15
3.2	Technical specifications	16
3.3	Dimension sketch	17
3.4	Installation conditions	19
3.5	Installation of the ComfoAir	19
3.5.1	Transport and unpacking	19
3.5.2	Checking the delivery	19
3.6	Mounting	20
3.6.1	Mounting on the ceiling	20
3.6.2	Mounting on the wall	20
3.6.3	Connection of the air ducts.....	21
3.6.4	Connection of the condensation drain	21
3.7	Commissioning the ComfoAir	22
3.7.1	Display on the unit.....	22
3.7.2	CC Ease panel	23
3.8	Programming air specifications	28
3.9	Maintenance by the installer	29
3.9.1	Inspecting the heat exchanger and fans	29
3.10	Malfunctions	30
3.10.1	Malfunction alerts on the digital operating device	30
3.10.2	Trouble shooting	31
3.10.3	Malfunctions (or problems) without alarms.....	34
3.11	Service parts	35
3.12	Wiring diagram: ComfoAir 200 – LEFT-HAND version	36
3.13	Wiring diagram: ComfoAir 200 – RIGHT-HAND version	37
3.14	Wiring diagram: ComfoAir 200 LUXE – LEFT-HAND version	38
3.15	Wiring diagram: ComfoAir 200 LUXE – RIGHT-HAND version	39

1 Introduction

This chapter provides general information on the ComfoAir.

1.1 Preface

In addition to this general chapter, this manual consists of:

- A part for the user,
- A part with technical specifications, and ...
- A part for the installer.



Carefully read this manual before use.

- User → Chapters 1 and 2.
- Installer → Chapters 1 and 3.

This manual provides all the information required for safe and optimal installation, operation and maintenance of the ComfoAir. It is also intended as a reference work for servicing, so that this can be carried out in a responsible manner. The device is subject to continuous development and improvement. As a result, the ComfoAir 200 may slightly differ from the descriptions.

NOTE

This manual has been compiled with the utmost care. However, no rights can be derived from it. In addition, we at all times reserve the right to change the contents of this manual, without prior notice.

1.2 CE marking

The device's name is ComfoAir 200. In the following it will be referred to as ComfoAir.

The ComfoAir is a balanced ventilation system with heat recovery in order to create healthy, balanced and energy-efficient ventilation in houses. The ComfoAir identification plate is shown below.

Type		Voltage	Hertz	Phase
Articlecode		Current		
		Power		
Capacitor	Protection class	Insulation class	Serial number	

1.3 Warranty and liability

1.3.1 General

The sales and warranty conditions for companies in the metal, plastic and technology industries, which apply to the ComfoAir, have been deposited with the Clerk of the District Courts of the Hague on 19th October 1998, under number 119/1998.

1.3.2 Guarantee conditions

The ComfoAir is covered by a manufacturer's warranty for a period of 24 months after fitting up to a maximum of 30 months after the date of manufacture. Warranty claims may only be submitted for material faults and/or construction faults arising during the warranty period. In the case of a warranty claim, the ComfoAir must not be dismantled without written permission from the manufacturer. Spare parts are only covered by guarantee, if they were supplied by the manufacturer and have been installed by an approved installer.

The warranty becomes invalid if:

- The guarantee period has elapsed;
- The device is used without filters;
- Parts are used that have not been supplied by the manufacturer;
- Non-authorised changes or modifications have been made to the unit.

1.3.3 Liability

The ComfoAir has been designed and manufactured for use in "balanced ventilation systems". Any other use is deemed unintended use and can lead to damage to the ComfoAir or personal injury, for which the manufacturer cannot be held liable.

The manufacturer is not liable for any damage originating from:

- Non-compliance with the safety, operating and maintenance instructions in this manual;
- The use of components not supplied or recommended by the manufacturer;
- Responsibility for the use of such components lies entirely with the installer;
- Normal wear and tear.

1.4 Safety

1.4.1 Safety regulations

Always comply with safety regulations in this manual. Non-compliance with the safety regulations, warnings, notes and instructions in this manual can cause personal injury or damage to the ComfoAir.

- The ComfoAir may only be installed, connected, rendered operational and maintained by a registered installer, unless otherwise indicated in this manual;
- Installation of the ComfoAir must be carried out in accordance with the general and locally applicable construction, safety and installation instructions of the local council, electricity and water boards or other agencies such as the GiW (Dutch Home Warranty Institute);
- Observe the safety regulations, warnings, comments and instructions as prescribed in this manual at all times;
- Keep this manual with the ComfoAir throughout its life;
- Instructions with regard to cleaning or replacing the filters of the intake and exhaust valves must be carefully observed;
- The specifications stated in this document may not be changed;
- Modifying the ComfoAir is not allowed;
- The ComfoAir is not suitable for connection to the three-phase mains;
- It is recommended to take out a maintenance contract so that the device is checked on a regular basis. Your supplier can provide you with a list of registered installers near you.

1.4.2 Safety provisions and measures

- The ComfoAir cannot be opened without using tools;
- It should not be possible to touch the fans and therefore ducting must be connected to the ComfoAir. The minimum duct length is 900 mm.

1.4.3 Pictograms used

The following pictograms are used in this manual:



Point of attention.



Risk of:

- **damage to the device;**
- **personal injury to the user, or;**
- **performance of the device is compromised if instructions are not observed carefully.**

2 For the user

This chapter describes how to operate the ComfoAir.

Congratulations, you are the owner of a ComfoAir 200, of Zehnder.
We wish you lots of comfort.

2.1 Glossary

The ComfoAir features:

- Balanced ventilation;
- Heat recovery;
- Bypass for free cooling;
- Frost protection;
- Chimney sweep programme;
- 0 - 10V input;
- Frost-free element (optional);
- Enthalpy (optional).

A concise explanation of these concepts/features is given in the paragraphs below.

2.1.1 Balanced ventilation

The ComfoAir is a balanced ventilation system. Balanced ventilation means that dirty air from the kitchen, the bathroom, the toilet(s) and possibly the storage room is extracted, while the same amount of fresh air is blown into the living room and bedrooms. Gaps under the doors ensure a good through-flow in the dwelling. The air circulation is in balance.

⚠ *Ensure that these gaps are never obstructed by draught excluders or deep-pile carpet, for example. The system will not function optimally.*

A balanced ventilation system consists of:

- ComfoAir 200 (A);
- Duct system for the supply of outdoor air (B) and the discharge of indoor air (C);
- Supply valves in the living room and bedrooms (D);
- Exhaust valves in the kitchen, bathroom, the toilet and (if present) the storage room (E).

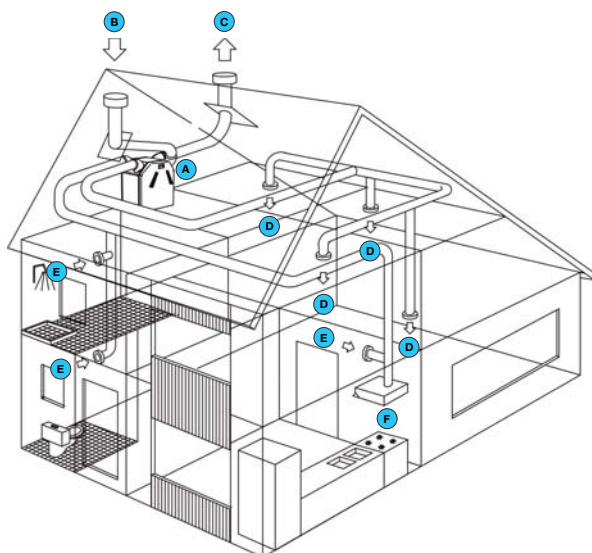

2.1.2 Heat recovery

Besides ensuring a healthy balance between incoming and outgoing air, the ComfoAir also provides the benefits of heat recovery. Heat recovery means that heat from the extracted air is transferred to the fresh, and usually colder, air from outside the building.

2.1.3 Bypass for free cooling

The bypass is often used during hot days in the summer season. By allowing colder outside air in at night, the indoor temperature of the dwelling can be kept low during hot days. The bypass works automatically. All you have to do is set the required comfort temperature.

2.1.4 Frost protection

The ComfoAir is also fitted with a frost protection device. This is an automatic protective system that temporarily reduces (or even briefly stops) the supply of outdoor air to the ComfoAir if there is a risk of freezing in the ComfoAir. This can occur in the event of moderate to sharp frost during the winter months.

2.1.5 Chimney sweep programme

The ComfoAir is fitted with an Chimney sweep programme. The Chimney sweep programme is used in houses that have a fireplace, as there is a risk of air being sucked back from the chimney. The Chimney sweep programme works automatically but requires activation by the installer.

2.1.6 0-10V input

The ComfoAir has a single input.

This input allows various different types of control system or sensor to be connected. Examples of the options include:

- CO₂ sensor; regulation using carbon dioxide levels;
- Moisture sensor; regulation using moisture levels;

2.1.7 Frost-free element (optional)

Fitting the optional frost-free element in the ComfoAir gives the added bonus that balanced ventilation remains intact for longer. In that case, the supply of cold outside air no longer needs to be reduced (so soon). The frost-free element is (de)activated automatically.

2.1.8 Enthalpy (optional)

The ComfoAir can be optionally fitted with an enthalpy exchanger. An enthalpy exchanger is less sensitive to freezing. An enthalpy system means the ComfoAir uses the frost-free element less, and no longer reduces the air supply from outside, though it does stop it in extreme cold.

2.2 Available operating elements

The ComfoAir is fitted with the following operating elements:

- Display on the unit;
- 3-position switch;
- Cordless 3-position switch;
- 3-position switch with malfunction indicators;
- Bathroom switch to temporarily select the highest ventilation position;
- CO₂ sensor;
- CC Ease panel.

A concise explanation of these operating elements is given in the paragraphs below.

2.2.1 Display on the unit

The ComfoAir can be operated by means of a digital display which is mounted on the unit.



	select menu		up
	OK		down
	supply off (led green)		supply on (led green)
	comfort temperature		

Shown in display

	Ventilation setting absent
	Ventilation setting low
	Ventilation setting medium
	Ventilation setting high
	Menu symbol
	Malfunction code (flashes)
	Bypass

Access to the menus

Se-quence	Press	Display	Description
1	MENU	P2	Time delay
2	▲	P9	Statussen
3	▲	P1	Statussen

Example

Setting bathroom switch delay

Se-quence	Press	Display	Description
1	MENU	P2	Time delay
2	OK	P21	Activation delay
3	▲	P22	Select 22
4	OK	30	Current setting
5	▼(10 x or press and hold)	20	Select 20
6	OK	P22	Sets the value to 20
7	MENU	P2	
8	MENU	1	Fan setting

2.2.2 3-position switch

A 3-position switch can be used to set the ventilation positions of the ComfoAir. One or multiple 3-position switches can be fitted in the house (e.g. in the kitchen). The following types of switches can be used:

- Type 1 → Standard 3-position switch;
- Type 2 → 3-position switch with LED for malfunction and filter alerts;
- Type 3 → Cordless 3-position switch with LED for malfunction and filter indication.

With regard to ventilation, if multiple position switches are available in the house, the ComfoAir will switch to the highest ventilation setting unless overruled by an automated software programme.

Setting the ventilation using 3-position switch(es)

A 3-position switch can be used to set 3 different ventilation positions.

- Position 1 → Low.
- Use for low ventilation levels.
- Position 2 → Normal.
- Use if you require normal ventilation.
- Position 3 → High.
- Use this position during cooking, showering and when additional ventilation is needed.



 **In addition to these 3 ventilation positions, the CC Ease panel or CC Luxe panel can be used to select an additional ventilation position (the absent setting).**

2.2.3 CO₂ sensor

The ComfoAir can also be operated using a CO₂ sensor. A CO₂ sensor can be used either as a 3-position switch or to determine manually the ventilation required by measuring CO₂ levels in the room concerned.

2.2.4 Bathroom switch

A bathroom switch can be used to temporarily set the ComfoAir in the highest ventilation level. This switch is mostly fitted in the bathroom to extract any excess moisture after showering, as soon as possible. The bathroom switches vary widely in model and are therefore not illustrated here.

If required, the bathroom switch can be turned on and off using a time delay entered via a digital operating device.

Activation delay

This ensures that the ComfoAir does not switch on at the highest setting when activated, but first waits for the activation delay to run its course.

 **If the bathroom switch is deactivated during the activation delay period, then the ComfoAir will remain at its current ventilation setting and not switch to the highest setting.**

 **The activation delay does not work with all types of bathroom switches (e.g. pulse switches). In that case, leave the activation delay at 0.**

Deactivation delay

This ensures that the ComfoAir does not switch back to the default (or preprogrammed) setting when deactivated, but first waits for the deactivation delay to run its course. Once the programmed deactivation delay is complete, the ComfoAir returns to the default (or preprogrammed) ventilation setting.

 **If the bathroom switch is turned off within the programmed deactivation delay period, then the deactivation function will be terminated.**

Light switch

The functions of the bathroom switch can also be integrated into a light switch.

2.2.5 CC Ease panel

The ComfoAir can be operated by means of a CC Ease panel, which can be ordered separately. The CC (Comfort Control) Ease panel is a digital operating device which can be mounted on the wall in the living room and from there communicates with the ComfoAir. The following overview summarizes the information that will be displayed.



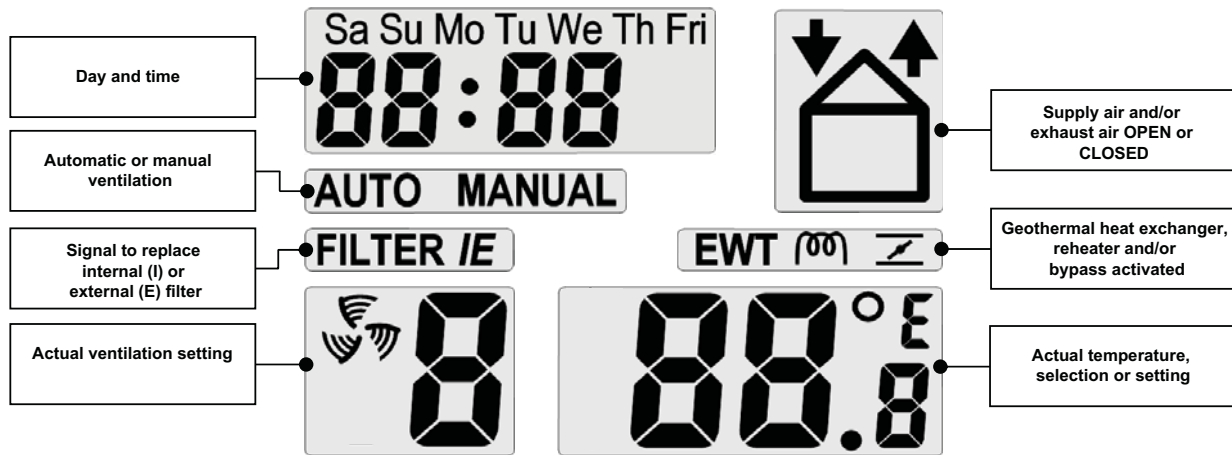

The CC Ease panel has a number of buttons to operate the ComfoAir and to enter the settings. These buttons are illustrated below.

	This button allows you to switch to the highest ventilation setting. - Press once → Temporary high setting ON. - Press twice → Temporary high setting OFF.
	This button allows you to switch between supply/exhaust. - Press once → SUPPLY OFF (and EXHAUST ON). - Press twice → EXHAUST OFF (and SUPPLY ON). - Press 3 times → SUPPLY and EXHAUST both ON.
	With this button you can read or set the comfort temperature. - Press for less than 2 seconds → READ. - Press for longer than 2 seconds → SET.
	This button allows you to programme two settings. - Press for less than 2 seconds → Programme ventilation setting (AUTO / MANUAL). - Press longer than 2 seconds → Programme date and time.
	This button allows you to programme different settings: - In P menu → Set values. - In main screen → Enter ventilation setting (A, 1, 2, 3).

2.3 Operating the CC Ease panel

The CC Ease panel is used for the following:

- Reading and setting the day and time;
- Reading and setting the comfort temperature;
- Reading and setting the ventilation volume;
- Activating the temporary high setting;
- Switching the supply and exhaust fan on/off;
- Setting a personal ventilation programme;
- Setting additional ventilation programmes/ options in the P menus.

A concise explanation of the above listing is given in the paragraphs below.

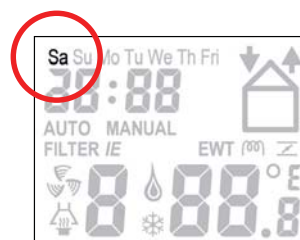

2.3.1 Setting the date and time

1. Press " " longer than 2 seconds.
2. Wait until the day, e.g. "Sa", starts blinking.
3. Select the correct day using " " or " ".

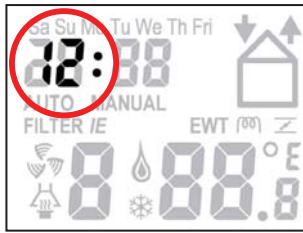

4. Press and briefly hold " ".
5. Wait until the hour, e.g. "12", starts blinking.
6. Select the correct hour using " " or " ".



7. Press and briefly hold "  " again.
8. Wait until the minutes, e.g. " 00 ", start blinking.
9. Select the correct minutes using "  " or "  ".





- 10 Press and briefly hold "  " again to return.

2.3.2 Reading and setting the comfort temperature





The comfort temperature can be read, but also set to the desired temperature. After entering the setting, the ComfoAir will automatically work to the temperature set.

Reading the comfort temperature

1. Press "  " briefly.
2. Wait until the comfort temperature appears.
3. Press "  " again to return.



Setting the comfort temperature

1. Press "  " longer than 2 seconds.
2. Wait until the comfort temperature, e.g. " 20.0 ", flashes.
3. Select the desired comfort temperature using "  " or "  ".
4. Press and briefly hold "  " to confirm.

2.3.3 Reading and setting the ventilation volume

Reading the ventilation volume

The current ventilation volume, e.g. "2", will always be displayed on the CC Ease panel. Normally the ComfoAir regulates the required ventilation volume **automatically**. During automatic ventilation mode "AUTO" will be displayed on the CC Ease panel.



Besides showing the programmed ventilation setting, the CC Ease panel also displays whether a temporary control system (such as a CO₂ sensor or a bathroom switch) is overriding the ventilation setting.

In the event a required ventilation setting is being overridden by a time delay function (such as the bathroom switch deactivation delay), a 't' is displayed in the bottom right-hand corner of the CC Ease panel.

In the event a required ventilation setting is being overridden by a signal from a sensor (such as a CO₂ sensor), an 'A' is displayed in the bottom right-hand corner of the CC Ease panel.

Setting the ventilation volume

The ventilation volume can also be set **manually** by increasing or decreasing it. A total of 4 ventilation volumes/levels can be set. They are:

- Setting A → Absent.
- Use when absent.

 **At level A, the house is ventilated using the minimum prescribed ventilation volume.**

- Setting 1 → Low.
- Use for low ventilation levels.
- Setting 2 → Normal.
- Use if you require normal ventilation.
- Setting 3 → High.
- Use this position during cooking, showering and when additional ventilation is needed.

 **With regard to ventilation, the ComfoAir will switch to the highest ventilation position set in the house unless overruled by an automated software programme.**

6. Wait until the ventilation setting is flashing in the bottom right-hand corner.
7. Select the desired ventilation setting using " \triangle " or " ∇ ".
8. Press " \odot ".
9. Programme the start time of the desired ventilation level.
 - Select the desired time in hours using " \triangle " or " ∇ ".
 - Press " \odot " again.
 - Wait until the minutes appear on the screen.
 - Select the required time in minutes using " \triangle " or " ∇ ".



- Press " \odot " again.
- Wait until the ventilation setting flashes.
- Select the desired ventilation level using " \triangle " or " ∇ ".



- Press " ∇ " to confirm.

10. Programme the next ventilation programme if required.
 - Repeat steps 1 to 9 to set the next ventilation programme.

2.3.7 Setting extra programmes

Some P menus in the CC Ease panel can be used to:

- Read the status of various ventilation programmes;
- Set time delays for various ventilation programmes on/off;
- Set time delays for various ventilation programmes.

 **The user can only use P menus P1, P2 and P9 to set additional programmes. The remaining P menus (P3 to P8) are for use by the installer only.**

Accessing the P menus

1. Press " \square " and " \triangle " simultaneously.
2. Wait until the "P menu" appears on the display.
3. Select the desired P sub-menu using " \triangle " or " ∇ ", e.g., P menu "2".



4. Press " \odot " to confirm the P menu.
5. Select the desired P sub-menu using " \triangle " or " ∇ ", e.g., P sub-menu "23".
6. Press " \odot " to confirm the P sub-menu.



Entering settings in P menus

7. Select a new value for the programme using " \triangle " or " ∇ ".
8. Press " \odot " to confirm.
9. Repeat steps 3 to 8 to set multiple ventilation programmes in succession.



 **The minimum and maximum values for the available ventilation programmes are preset in the software.**

Returning to the main menu

10. Press " \square " twice.



The ventilation volume can be set as follows:

1. Press "▲" to increase the ventilation volume.
2. Press "▼" to decrease the ventilation volume.

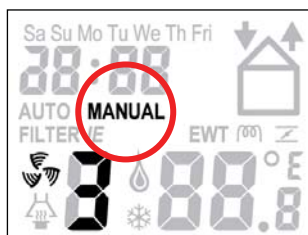

During manual ventilation, the CC Ease panel will not display "AUTO", but "MANUAL".

3. Press "☑" to return to automatic ventilation.



2.3.4 Switching temporary High on

1. Press "☑" longer than 2 seconds.
2. Wait until '3t' appears.

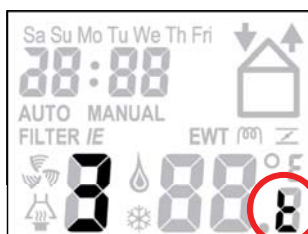

Once the programmed time delay is complete, the ComfoAir automatically switches back to the previous ventilation setting.

2.3.5 Switching the supply and exhaust fan on/off

1. Press "🏠" once to switch off the supply fan.

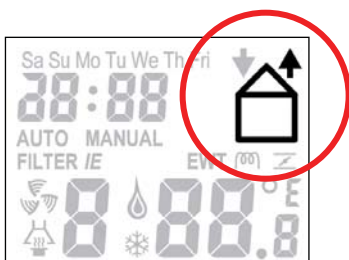

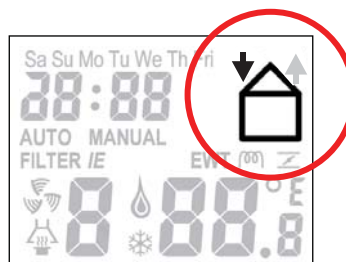

This mode can be used when the windows are open during the summer. In that case, fresh air is not supplied via the supply fan, but through the open windows.

2. Press "🏠" twice to switch the exhaust fan off (and to switch the supply fan on).

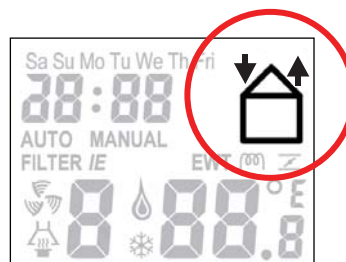

3. Press "🏠" three times to switch the supply and exhaust fans on again.



 **Bear in mind that switching off the supply or exhaust fan will temporarily immobilize your balanced ventilation system.**

2.3.6 Setting the ventilation programme

The ComfoAir has a factory default ventilation setting.

If required, you can change the default ventilation setting to suit your individual situation. Examples include weekday and weekend programmes.

The ventilation volume can be changed/set as follows:

1. Press together for 2 seconds icons "☑" and "☑".
2. Wait until the ventilation programme appears.
3. Programme the desired day or series of days.
4. Select the desired option using "▲" or "▼".



You can choose from:

- Weekend: "SaSu";
 - Working week: "MoTuWeThFr";
 - Week: "SaSuMoTuWeThFri";
 - Separate days: "Sa", "Su", "Mo", "Tu", "We", "Th" and "Fri".
5. Press "☑".

Menu P1 → Status of programmes

		Ventilation programmes
Sub-menu	Description	Activated
P11	Is menu 21 currently active?	Yes (1) / No (0)
P12	Is menu 22 currently active?	Yes (1) / No (0)
P13	Is menu 23 currently active?	Yes (1) / No (0)
P14	Is menu 24 currently active?	Yes (1) / No (0)
P15	Is menu 25 currently active?	Yes (1) / No (0)
P16	Is menu 26 currently active?	Yes (1) / No (0)

Menu P2 → Setting time delays

Sub-menu	Description	Time delay values		
		Minimum	Maximum	Standard
P21 (Optional) Note: Only applies to systems fitted with a corded switch and a second switch in the bathroom.	- Low voltage input Activation delay for the bathroom switch (to switch to high position). • 'x' minutes after operating the bathroom switch, the ComfoAir switches to the HIGH SETTING.	0 Min.	15 Min.	0 Min.
P22 (Optional) Note: Only applies to systems fitted with a corded switch and a second switch in the bathroom.	- Low voltage input Deactivation delay for the bathroom switch (to switch to normal position). • 'x' minutes after operating the bathroom switch, the ComfoAir switches back to the NORMAL SETTING.	0 Min.	120 Min.	30 Min.
P23 (Optional) Note: Only applies to systems fitted with a corded switch.	Deactivation delay for ventilation position 3. • If ventilation setting 3 (high) is switched on briefly (< 3 sec), the ComfoAir remains at ventilation setting 3 in accordance with the time set in this menu. If the position switch or RF remote control is operated during this lagging time, the ComfoAir will instantly revert to the ventilation position as set at that time.	0 Min.	120 Min.	0 Min.

Sub-menu	Description	Time delay values		
		Minimum	Maximum	Standard
P24	Filter warning <ul style="list-style-type: none"> Here the user can indicate when the "FILTER DIRTY" alert must appear. 	10 weeks	26 weeks	16 weeks
P25 Note: Only applies to systems fitted with an RF switch.	Deactivation delay for ventilation setting 3 (using "☺"). <ul style="list-style-type: none"> After pressing "☺" BRIEFLY (< 2 sec.), the ComfoAir runs at the HIGH setting for 'x' minutes and then automatically returns to the programmed setting. 	1 Min.	20 Min.	10 Min.
P26 Note: Only applies to systems fitted with an RF switch.	Deactivation delay for ventilation setting 3 "☺". <ul style="list-style-type: none"> After pressing "☺" for LONGER (> 2 sec.), the ComfoAir runs at the HIGH setting for 'x' minutes and then automatically returns to the programmed setting. 	1 Min.	120 Min.	30 Min.
P27 Note: Only applies to systems fitted with a CC Ease panel.	Time for the temporary high setting. <ul style="list-style-type: none"> After pressing "☺" continuously (>2 sec.), the ComfoAir runs at the high setting for 'x' minutes and then automatically returns to the programmed setting. 	0 Min.	120 Min.	30 Min.

Menu P9 → Status of programmes (from menu P5)

Sub-menu	Description	Ventilation programmes
		Activated
P90	Open fire programme active?	Yes (1) / No (0)
P91	Bypass Open (=Yes) / Closed (=No)?	Yes (1) / No (0)
P92	Geothermal heat exchanger valve (EWT) Open (=Yes) / closed (=No)	Yes (1) / No (0)
P93	Reheater active?	Yes (1) / No (0)
P94	0 – 10 V programme active?	Yes (1) / No (0)
P95	Frost protection active?	Yes (1) / No (0)
P96	Extractor hood programme active?	Yes (1) / No (0)
P97	Enthalpy programme active?	Yes (1) / No (0)

2.4 Maintenance by the user

As a user of the ComfoAir, you must carry out the following maintenance:

- Replacing the filters;
- Cleaning the valves (in the dwelling).

A concise explanation of these maintenance activities is given in the paragraphs below.

⚠ Failure to carry out (periodic) maintenance on the ComfoAir ultimately compromises the performance of the ventilation system.

2.4.1 Replacing the filters

If so indicated on the digital operating device, you must clean or replace the filters.

- “ FILTER / ” → The internal filters must be replaced.
- “ FILTER E ” → The external filters* must be cleaned or replaced.

The CC Ease panel will display one of the above filter warnings.

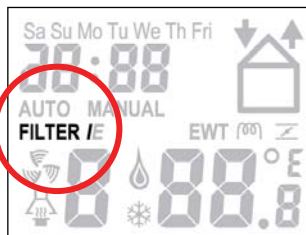

You will see the message “FIL” and “tEr” appearing alternately on the display.

👉 The internal filters are included in the standard configuration of the ComfoAir. The external filters (optional) form part of the ducting of the ventilation system yet do not form part of the ComfoAir.

To replace ...

If the filters need replacing, follow this procedure:

- Press “  ” on the CC Ease panel or “OK” on the display until the filter alert disappears.
- Unplug the ComfoAir.
- Remove the filter caps (A) from the ComfoAir.

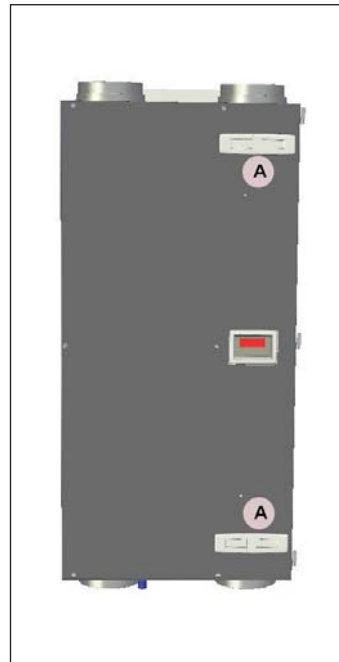

- Remove the old filters (B) from the ComfoAir

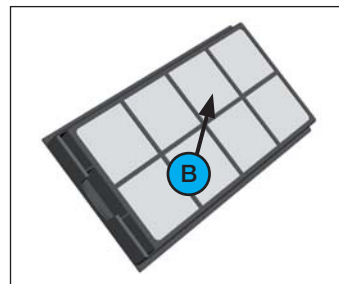

- Slide the new filter back into the ComfoAir.
- Refit the filter caps (A) to the ComfoAir.
- Plug the ComfoAir back in.

⚠ When using the ComfoAir for the first time, it is recommended to replace the filters and clean the valves first, as during the construction phase the ventilation system could have become dirty with building dust.

⚠ Replace the filters (at least) once a year.

2.4.2 Cleaning the valves (in your dwelling)

The ventilation system may be fitted with the following valves:

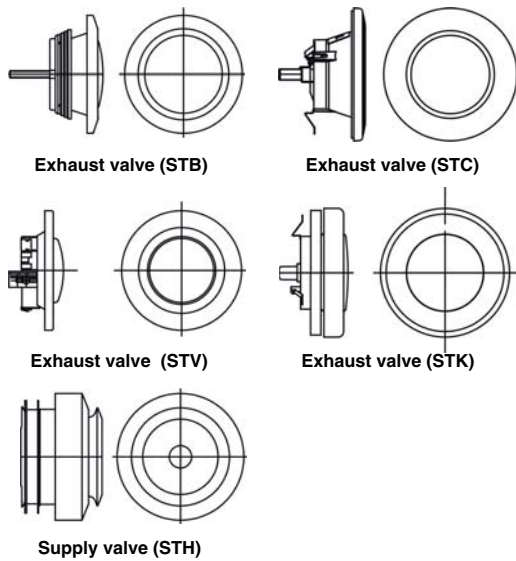

You must clean the valves (at least) twice a year:

- Remove the valve from the wall or ceiling;
- Clean the valve in a solution of soap and warm water;
- Rinse the valve thoroughly and wipe dry;
- Place the valve back WITH EXACTLY THE SAME SETTING (and IN THE SAME HOLE);
- Repeat this procedure for the other valves.

About the valve settings...

The installer will have set all the valves to ensure the optimum performance of the ventilation system. Therefore, do not change the setting of the valves.

⚠ After cleaning, make sure that all valves are placed back with the same setting (and in exactly the same ventilation hole in the wall or ceiling) AT ALL TIMES. Otherwise, system performance will be compromised.

The ventilation air is supplied and discharged by means of valves. Gaps under doors in the dwelling ensure that the air flows in the right direction. In order to ensure that the correct ventilation volumes are maintained in the rooms, the following must be observed:

- Do not seal the gaps;
- Do not change the settings of the valves;
- Do not replace the valves with one another.

2.5 Malfunctions

Malfunctions in the ComfoAir are reported as follows:

- The malfunction alert appears on the CC Ease panel;
- The malfunction indicator on the 3-position switch lights up;
- The malfunction alert appears on the display.

A concise explanation of these maintenance activities is given in the paragraphs below.

2.5.1 Malfunction alerts on the digital operating device

In the event of a malfunction, the corresponding malfunction code will be displayed on the digital operating device of the ComfoAir. The digital operating device will always show an 'A' or an 'E', with a number as a suffix. Please refer to the malfunction overview to find out the meaning of the relevant malfunction alert.



2.5.2 3-position switch with malfunction indicators

The 3-position switches that are fitted with a malfunction indicator show when a malfunction has occurred. Depending on the type of the 3-position switch, this is done in one of the following two ways:

- 3-position switch with malfunction indicator.
In the event of a malfunction (or in the event of a filter dirty alert) the indicator lights up.
- Cordless 3-position switch with malfunction indicator.

The malfunction indicators will light up once this 3-position switch is used. One indicator will light up green to indicate communication has been established. Subsequently, in the event of a malfunction (and in the event of a filter dirty alert) both indicators will flash red 3 times. After that, both indicators will light up green once more.



 **The malfunction indicator on the 3-position switch will not light up in the event of malfunctions alone, but will also light up in the event of filter cleaning warnings.**

2.5.3 What to do in the event of a malfunction

In the event of a malfunction, contact the installer. Note down the malfunction code that appears on the digital operating device. Make a note of your ComfoAir type. This is given on the identification plate on the top of the ComfoAir.

The system should not be unplugged, unless the ComfoAir must be taken out of service due to a serious malfunction, or for filter cleaning/replacement or any other compelling reasons.



When the unit is unplugged, the dwelling will no longer enjoy mechanical ventilation, and this can lead to problems with damp and mould. Long-term deactivation of the ComfoAir must therefore be prevented.

2.6 End of useful life

Consult with your supplier about what you should do with the ComfoAir at the end of its useful life. If the ComfoAir cannot be returned to the supplier, avoid disposing of it with the domestic waste, and ask your local council about the options for recycling the components or processing the materials in an environmentally friendly manner.

Furthermore, do not dispose of batteries from the cordless switches with the normal waste, but bring them to the specially designated disposal locations.

3 For the Installer

This chapter describes how to fit the ComfoAir.

3.1 ComfoAir 200

The standard ComfoAir 350 configuration consists of:

- External casing (A) of coated sheeting;
- Interior (B) of high-quality, expanded polypropylene (E)PP;
- 4 connections (C) for the air ducts;
- 2 G4 filters (D) for air purification;
- 2 energy-efficient DC motors (E) with high-yield fan;
- HR (High Yield) heat exchanger (with optional moisture exchanger) (F);
- Connector panel (H2) with connections for the CC Ease panel, the enthalpy exchanger and the 0 – 10V control sensors, CC Luxe panel, Reheater, Geothermal heat exchanger and all other luxury options;
- PCB panel (H1) with connections for the fans, the bypass, the Frost-free element, temperature sensors (T1 to T4), the 3-position switch with or without malfunction and filter indication (optional) and the bathroom switch (optional);
- Identification plate (I) detailing information on the ComfoAir (not visible);
- Condensation drain (J) to drain the condensation of the warm return air;
- Sticker (K) detailing the air connections (not visible);
- 230V plug (L);
- Display (G) to read data, and for programming procedures;
- 2 Filtercaps (M);
- 4 Ceiling mounting brackets (N) or 1 Wall mounting bracket (not visible).

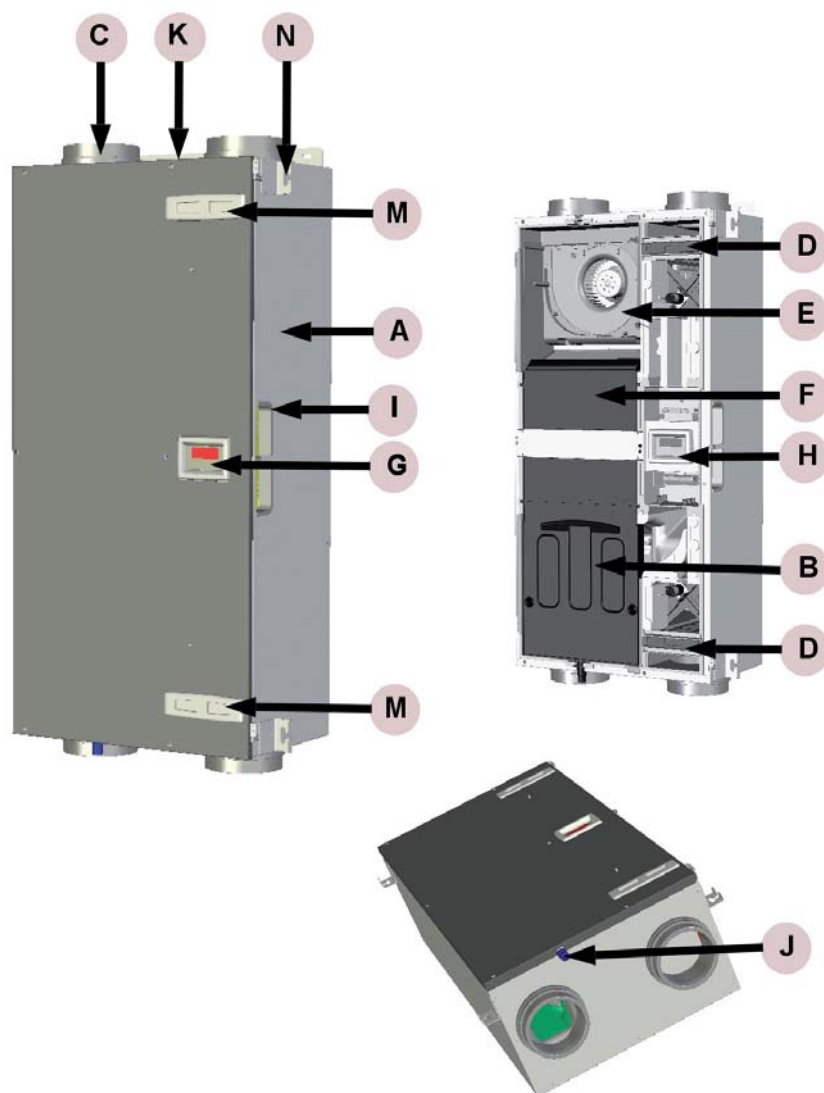

3.2 Technical specifications

ComfoAir 200 nL (normal air volumes)

Position	Ventilation capacity	Value
ABSENT SETTING	20 m ³ /h bij 3 Pa	9 W
LOW SETTING	70 m ³ /h bij 10 Pa	17 W
MEDIUM SETTING	120 m ³ /h bij 30 Pa	30 W
HIGH SETTING	185 m ³ /h bij 68 Pa	68 W
MAXIMUM	255 m ³ /h bij 125 Pa	143 W
Position	Ventilation capacity	Value
ABSENT SETTING	20 m ³ /h bij 3 Pa	0.08 A
LOW SETTING	70 m ³ /h bij 10 Pa	0.14 A
MEDIUM SETTING	120 m ³ /h bij 30 Pa	0.25 A
HIGH SETTING	185 m ³ /h bij 68 Pa	0.55 A
MAXIMUM	255 m ³ /h bij 125 Pa	1.10 A

Electricity	
Power supply	230/50 V/Hz
Cos.phi	0,48 - 0,57

Supply fan noise level

Position	Ventilation capacity	Value
ABSENT SETTING	20 m ³ /h bij 3 Pa	37 db(A)
LOW SETTING	70 m ³ /h bij 10 Pa	49 db(A)
MEDIUM SETTING	120 m ³ /h bij 30 Pa	59 db(A)
HIGH SETTING	185 m ³ /h bij 68 Pa	66 db(A)
MAXIMUM	255 m ³ /h bij 125 Pa	73 db(A)

Exhaust fan noise level

Position	Ventilation capacity	Value
ABSENT SETTING	20 m ³ /h bij 3 Pa	36 db(A)
LOW SETTING	70 m ³ /h bij 10 Pa	39 db(A)
MEDIUM SETTING	120 m ³ /h bij 30 Pa	44 db(A)
HIGH SETTING	185 m ³ /h bij 68 Pa	52 db(A)
MAXIMUM	255 m ³ /h bij 125 Pa	60 db(A)

ComfoAir 200 HL (high air volumes)		
------------------------------------	--	--

Position	Ventilation capacity	Value
ABSENT SETTING	20 m ³ /h bij 3 Pa	9 W
LOW SETTING	90 m ³ /h bij 13 Pa	20 W
MEDIUM SETTING	185 m ³ /h bij 68 Pa	68 W
HIGH SETTING	245 m ³ /h bij 120 Pa	128 W
MAXIMUM	255 m ³ /h bij 125 Pa	143 W
Position	Ventilation capacity	Value
ABSENT SETTING	20 m ³ /h bij 3 Pa	0.08 A
LOW SETTING	90 m ³ /h bij 13 Pa	0.16 A
MEDIUM SETTING	185 m ³ /h bij 68 Pa	0.55 A
HIGH SETTING	245 m ³ /h bij 120 Pa	0.99 A
MAXIMUM	255 m ³ /h bij 125 Pa	1.10 A

Electricity	
-------------	--

Power supply	230/50 V/Hz
Cos.phi	0,48 - 0,57

Supply fan noise level		
------------------------	--	--

Position	Ventilation capacity	Value
ABSENT SETTING	20 m ³ /h bij 3 Pa	37 db(A)
LOW SETTING	90 m ³ /h bij 13 Pa	53 db(A)
MEDIUM SETTING	185 m ³ /h bij 68 Pa	66 db(A)
HIGH SETTING	245 m ³ /h bij 120 Pa	72 db(A)
MAXIMUM	255 m ³ /h bij 125 Pa	73 db(A)

Exhaust fan noise level		
-------------------------	--	--

Position	Ventilation capacity	Value
ABSENT SETTING	20 m ³ /h bij 3 Pa	36 db(A)
LOW SETTING	90 m ³ /h bij 13 Pa	42 db(A)
MEDIUM SETTING	185 m ³ /h bij 68 Pa	52 db(A)
HIGH SETTING	245 m ³ /h bij 120 Pa	56 db(A)
MAXIMUM	255 m ³ /h bij 125 Pa	60 db(A)

General Specifications	
------------------------	--

HE Exchanger Material	Polystyrene
Interior Material	(E)PP / ABS
Thermal Yield	95%
Mass	30 kg

3.3 Dimension sketch

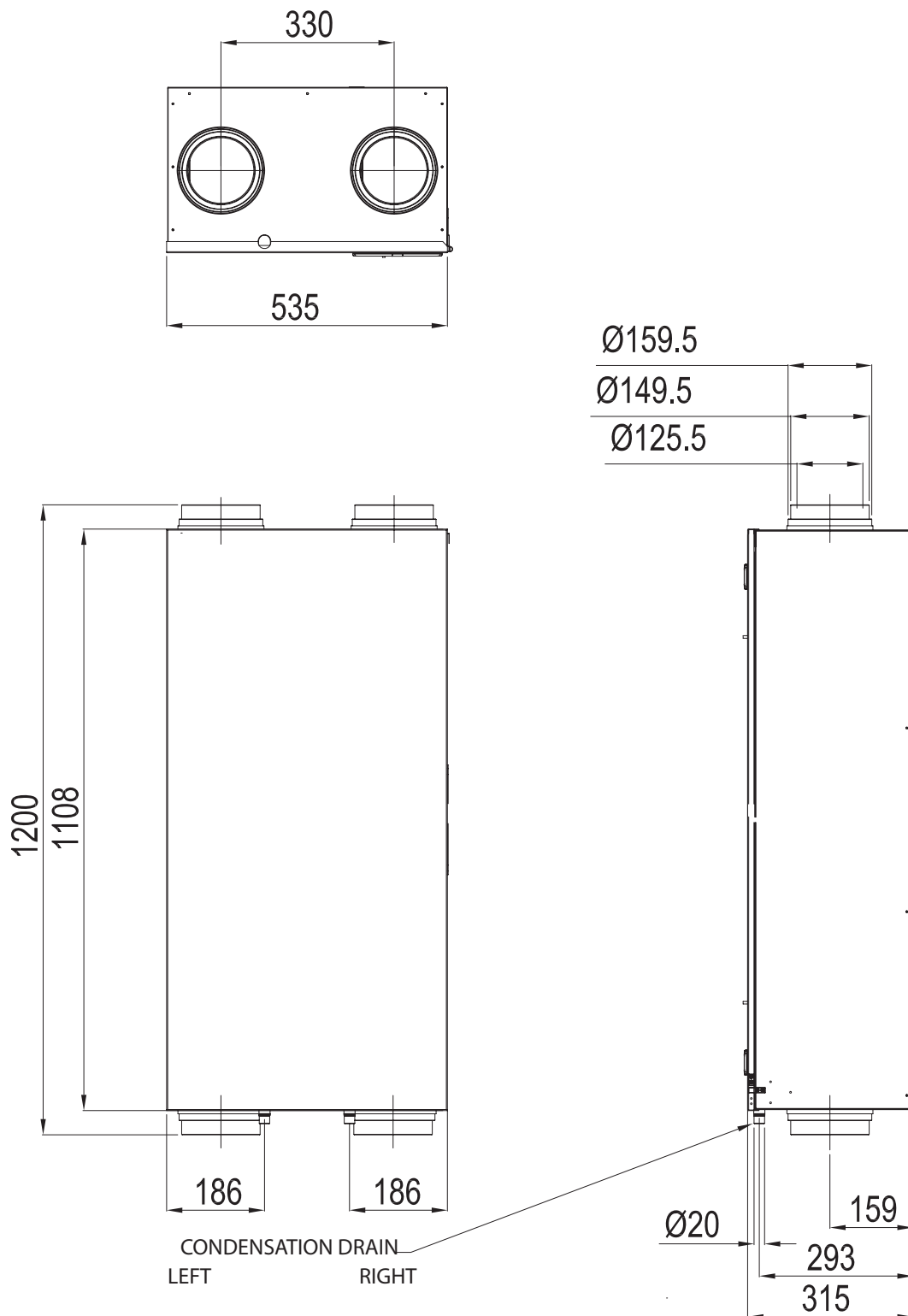

3.4 Installation conditions

In order to determine whether the ComfoAir can be installed in a certain area, the following aspects must be taken into account:

- The ComfoAir must be installed according to the general and locally applicable safety and installation regulations of power and water companies, as well as the instructions in this manual.
- The system must be fitted to allow sufficient room around the ComfoAir for the air connections and supply and exhaust ducts as well as for carrying out maintenance activities.
- The room must offer the following provisions:
 - Air duct connections.
 - 230V electrical connection.
 - Provisions for the condensation drain.
- The roof vents should be made airtight and damp-proof. The outside air supply duct and the air exhaust duct between the roof/wall passage and the ComfoAir must be rendered damp proof. This prevents the formation of condensation on the outside of the ducts.
- To prevent unnecessary temperature loss in either the summer or the winter, we recommend fitting thermal and damp-proof insulation to the supply ducts from the ComfoAir up to the supply valves.
- The air exhaust duct must be fitted with a double-walled or insulated roof passage. This prevents the formation of condensation between the roof boarding. In addition, the air exhaust duct must drain in the direction of the ComfoAir.
- The ComfoAir must be installed in a frost-free space. The condensation must be drained off frost-free, at a gradient, using a siphon.
- The cable used to connect the CC Ease panel must have the following specifications:
 - Cable type: shielded twisted pair 4x0.34m2.
 - Cable length: 10 m maximum.
- We recommend fitting both the intake and the exhaust connections of the ComfoAir with silencers located directly against the unit. For further information, please contact Zehnder.



An opening has purposely been left under the inside doors in order to ensure effective and draught-free airflow in the house. If these openings are obstructed, due to draught excluders or deep-pile carpet, the airflow in the house will stagnate. As a result, system performance will be compromised or fail altogether.

3.5 Installation of the ComfoAir

3.5.1 Transport and unpacking

Take the necessary precautions when transporting and unpacking the ComfoAir.



Make sure the packing material is disposed of in an environmentally friendly manner.

3.5.2 Checking the delivery

Contact your supplier immediately in case of damage or an incomplete delivery. The delivery must include:

- ComfoAir 200;
- Check the identification plate to ensure that it is the required type;
- Ceiling mounting set;
- Wall mounting bracket;
- Manual.

The ComfoAir is supplied in the following types:

Type	
ComfoAir 200 L	ComfoAir 200 L RF
ComfoAir 200 R	ComfoAir 200 R RF

Type	
ComfoAir 200 L Luxe	ComfoAir 200 L VV Luxe
ComfoAir 200 R Luxe	ComfoAir 200 R VV Luxe

Meaning of the suffices:

- L = Left.
- R = Right.
- RF = Cordless 3-position switch.
- VV = Frost-free element.
- Luxe = Refers to the version with the connector PCB.

CC Ease panel (optional) can be ordered separately.

3.6 Mounting

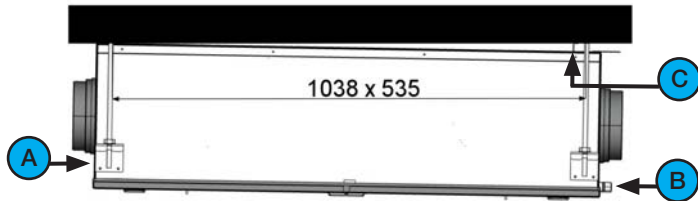

The ComfoAir 200 can be mounted two ways:

- On the ceiling;
- On the wall.

3.6.1 Mounting on the ceiling

Mount the ComfoAir 200 to a ceiling with a minimum mass of at least 200 kg/m².

- **Fasten** the four mounting brackets (A) (using the screws supplied) to the sides of the ComfoAir.
- **Fasten** the two spacer brackets (C) (using the screws supplied) to the top of the ComfoAir on the side of the condensation drain (B). As long as the ceiling is level, this ensures a run-off of 2% to the condensation drain.
- **Mark** the position of the mounting points on the ceiling.
- **Mount** four pieces of studding (M8 or M10) extending 290 cm below the ceiling.
- **Screw** suitable (securing) rings and nuts on the four rods.
- **Hang** the unit on the rods and then screw the locknuts tight.

Allow a 2% run-off to the condensation drain. If the ceiling is horizontal, the spacer brackets will automatically ensure that the ComfoAir hangs at the correct angle.

- **Mount** the condensation drain (optional extra) to the ComfoAir with a coupling or removable pipe.
- **Ensure** that there is enough room under the ComfoAir for carrying out maintenance.

The ComfoAir does not require any space at the sides for effective operation.

 **Do not mount the side of the ComfoAir against the wall due to the risk of impact sound.**

3.6.2 Mounting on the wall

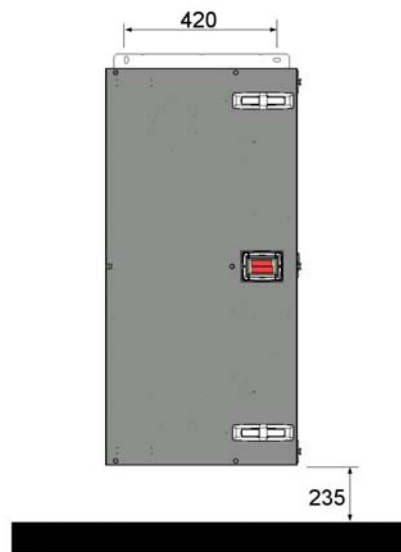

Mount the ComfoAir against a wall with a minimum mass of 200 kg/m².

- **Using** a spirit level, fix the mounting bracket horizontally to the wall. Use M8 anchor bolts. Make sure there is enough space under the ComfoAir to mount the siphon.
- **Hang** the unit in the mounting bracket.
- **Mount** the condensation drain (not supplied) under the ComfoAir. The stated dimension of 235 mm is an indication only, and is dependent on the type of condensation drain selected.
- **Make sure** to leave a minimum space of 1 metre in front of the ComfoAir in view of the necessary maintenance work.

The ComfoAir does not require any space at the sides for effective operation.

 **Do not mount the side of the ComfoAir against the wall due to the risk of impact sound.**

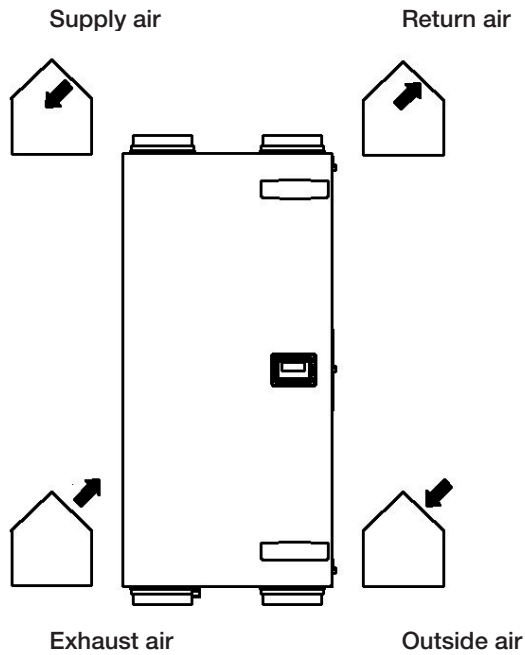

ComfoAir 200 - Left

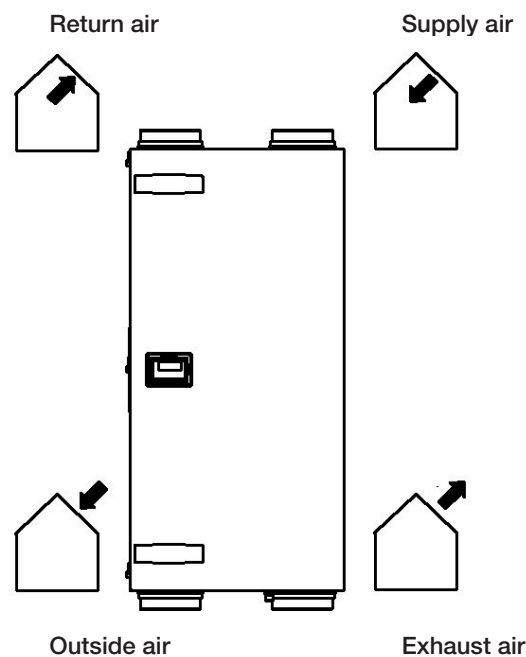

ComfoAir 200 - Right

3.6.3 Connection of the air ducts

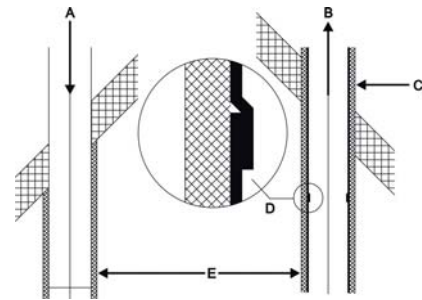

Install a silencer of at least 1 metre straight directly onto the supply and return connections. For relevant advice, please contact Zehnder.

Subsequently, the air ducts to be connected, with a minimum \varnothing of 125 mm, must be installed with as little air resistance as possible and must be free from air leakage.

- **Do not use flexible ducting** and leave room for mounting silencers. We recommend that the ventilation system be fitted with intake and exhaust valves made by Zehnder.
- **Insulate the outside air supply and the air exhaust duct** between the roof/wall passage to render the ComfoAir damp proof. This prevents the formation of condensation on the outside of the ducts.

3.6.4 Connection of the condensation drain

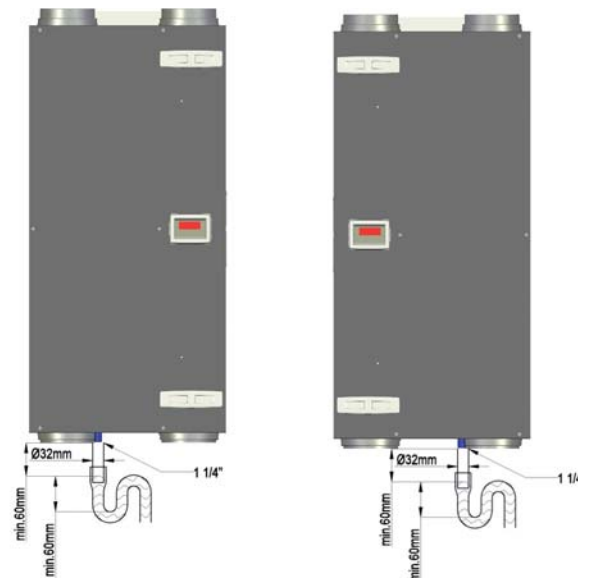

Warm exhaust air is cooled by the outside air in the heat exchanger. This causes the moisture in the indoor air to condense in the heat exchanger. The condensation water created in the heat exchanger is fed to a PVC condensation drain.

The connection for the condensation drain has an external diameter of 20 mm and a ledge of 21.2 mm. It is located underneath the ComfoAir.

- Connect the condensation drain, via a pipe with coupling or hose, to the water seal of the domestic waste-water system.



For future maintenance activities the condensation drain must be removable.

- Position the upper edge of the water seal at least 40 mm underneath the condensation drain of the ComfoAir.
- Make sure that the outer end of the pipe or tube exits below the water level.
- Ensure the condensation drain pipe on ceiling-mounted units has a run-off to the siphon of at least 2%.



Ensure that the water seal connected to the domestic waste-water system is always full of water.



Also ensure that the end of the hose is at least 60 mm under the level of the water. This prevents the ComfoAir from sucking in any leakage air.

3.7 Commissioning the ComfoAir

After installation, the ComfoAir must be commissioned.

This can be done via the P menus on the digital operating device. These P menus can be used to enter various settings (ventilation programmes, in particular) for the ComfoAir. An overview of the available P menus is given below:

Menu	Options
P1	Reading statuses (from menu P2)
P2	Setting time delays
P3	Setting the ventilation levels
P4	Reading the temperatures
P5	Setting additional programmes
P6	Setting additional programmes
P7	Reading and resetting malfunctions (and system information)
P8	Setting 0-10V inputs
P9	Reading statuses (from menu P5)

P menu P1, P2 and P9 can be accessed by the user, mainly to read statuses and set time delays. The remaining P menus P3 to P8 are intended solely for the installer.



The ComfoAir's bypass valve will not work for the first 4 minutes after a power cut unless the programme mode is activated.

3.7.1 Display on the unit

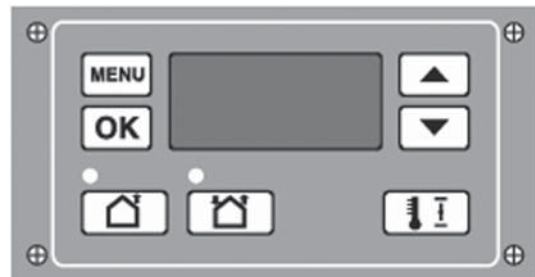

	select		up
	OK		down
	supply off (led green)		supply on (led green)
	comfort temperature		

Shown in display

	Ventilation setting absent
	Ventilation setting low
	Ventilation setting medium
	Ventilation setting high
	Menu symbol
	Malfunction code (flashes)
	Bypass

Access to the menus

Se-quence	Press	Display	Description
1	MENU	P2	Time delay
2	(3 seconds)	P3	Press the buttons at the same time
3		P4	Temperatures
4		P5	Settings
5		P6	Settings
6		P7	Malfunction / Reset / Self-test
7		P8	0 - 10V Inputs
8		P9	Statussen

Example



Setting bathroom switch delay

Se-quence	Press	Display	Description
1	MENU	P2	Time delay
2	(3 seconds)	P3	Press the buttons at the same time Ventilation
3	OK	P30	Exhaust fan Position A
4	(5x)	P35	Select P35
5	OK	50	Current setting
6	(10 x or press continuously)	40	Select 40
7	OK	P35	Value is 40
8	MENU	P3	
9	MENU	1	Fan setting

3.7.2 CC Ease panel



Accessing the P menus



- 1 Press "  " and "  " simultaneously.
- 2 Wait until the "P menu" appears on the display.



 **P menus P1, P2 and P9 can now be accessed.**





- 3 Press and hold "  " and "  " for 2 seconds, simultaneously.
- 4 Wait until "P menu" P3 appears on the display.

 **P menus P3 to P8 can now be accessed.**



- 5 Select the desired P menu, e.g. " 5 ", using "  " or "  ".
- 6 Press "  " to confirm the P menu.





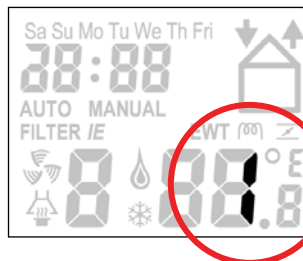

- 7 Select the desired P sub-menu, e.g. " 51 ", using "  " or "  ".
- 8 Press "  " to confirm the P sub-menu.

Entering settings in P menus

 **The minimum and maximum values for the available settings parameters are preset in the software.**



- 9 Select a value for the parameter using "  " or "  ".
- 10 Press "  " to confirm.
- 11 Repeat steps 5 to 10 to set multiple parameters in succession.
Or
Press "  " to return to the P menu.

Returning to the main menu



- 12 Press "  " twice.

Menu P3 → Setting ventilation programmes

Submenu	Description	Ventilation programme values		
		Minimum	Maximum	Standard
P30	Setting the capacity (in %) of the exhaust fan in ABSENT POSITION.	0% or 15%	97%	nL / HL 15% / 15%
P31	Setting the capacity (in %) of the exhaust fan in LOW POSITION.	16%	98%	nL / HL 35% / 40%
P32	Setting the capacity (in %) of the exhaust fan in MEDIUM POSITION.	17%	99%	nL / HL 50% / 70%
P33	Setting the capacity (in %) of the exhaust fan to HIGH.	18%	100%	nL / HL 70% / 90%
P34	Setting the capacity (in %) of the supply fan to ABSENT.	0% or 15%	97%	nL / HL 15% / 15%
P35	Setting the capacity (in %) of the supply fan in LOW LEVEL MODE.	16%	98%	nL / HL 35% / 40%
P36	Setting the capacity (in %) of the supply fan in MEDIUM LEVEL MODE.	17%	99%	nL / HL 50% / 70%
P37	Setting the capacity (in %) of the supply fan in HIGH LEVEL MODE.	18%	100%	nL / HL 70% / 90%
P38	Current capacity (in %) of the exhaust fan.	-	-	Current %
P39	Current capacity (in %) of the supply fan.	-	-	Current %

Menu P4 → Reading the temperatures

Submenu	Description	Temperature values		
		Minimum	Maximum	Standard
P41	Comfort temperature	12 °C	28 °C	20 °C
P45	Current value of T1 (= outside air temperature)	-	-	Current °C
P46	Current value of T2 (= supply air temperature)	-	-	Current °C
P47	Current value of T3 (= return air temperature)	-	-	Current °C
P48	Current value of T4 (= exhaust air temperature)	-	-	Current °C





Menu P5 → Setting additional programmes

Submenu	Description	Additional programme values		
		Minimum	Maximum	Standard
P50	Activation of the open fire programme.	0 (= No)	1 (= Yes)	0
P51	Confirming the presence of a frost-free element	0 (= No)	1 (= Yes)	0
	<p>Note: Only change if a frost-free element is installed afterwards. If the ComfoAir must be reset to the original factory settings using P75, the default value of the frost-free element is set to "NOT FITTED".</p> <ul style="list-style-type: none"> • Check the presence of the frost-free element following a general system reset via menu P75. 			
P52	Setting the frost-free programme. • 0; Guaranteed protection. • 1; High protection. • 2; Nominal protection. • 3; Economy.	0	3	2
	<p>Note: In GUARANTEED PROTECTION MODE the frost-free element is switched on soonest; this level offers the best guarantee of balanced ventilation. Vice versa, in ECONOMY MODE the frost-free element switches on at the last possible moment; balanced ventilation is not guaranteed in this mode.</p> <p>When commissioning the ComfoAir, the frost-free programme can usually be left at level 2: NOMINAL MODE (factory setting). In areas with frequent cold spells in winter (frequent periods of -10°C or lower), level 1 should be selected: HIGH PROTECTION or even level 0: GUARANTEED PROTECTION.</p>			
P54	Confirming the presence of a bypass.	0 (= No)	1 (= Yes)	1
	<p>Note: The standard ComfoAir configuration includes a bypass. Therefore, leave the value at '1'.</p>			
P56	Setting the required air volume in the house. • nL: "normal air volume". • HL: "high air volume".	nL	HL	HL
	<p>Note: Setting the air volume in P56 (to "nL" or "HL") is the starting point for programming the air specifications and setting the fans.</p>			
P57	Setting the ComfoAir type. • Li = "Left-hand version". • Re = "Right-hand version".	Li	Re	Li
	<p>Note: The ComfoAir is correctly preprogrammed at the factory. • See also the identification plate for these details.</p>			
P58	Enter controller priorities. • 0; Preference to highest air setting INCLUDING analogue input • 1; Preference to highest air setting EXCLUDING analogue input	0	1	0
P59	Confirming the presence of an enthalpy exchanger. • 0; Enthalpy exchanger fitted • 1; Enthalpy exchanger with RH sensor. • 2; Enthalpy exchanger without RH sensor.	0 (= No)	2 (= Yes)	0
	<p>Note: If an enthalpy exchanger without a sensor is selected, then the enthalpy programme will not be activated and malfunction alerts EA1 & EA2 will never occur.</p>			

Menu P6 → Setting additional programmes

Submenu	Description	Additional programme values		
		Minimum	Maximum	Standard
P60	Confirming the presence of a geothermal heat exchanger (EWT). <ul style="list-style-type: none"> • 0; Geothermal heat exchanger not fitted • 1; Geothermal heat exchanger fitted • 3; Geothermal heat exchanger unregulated. 	0 (= No)	3 (= Yes)	0
Note: If a valveless geothermal heat exchanger is fitted, then the unregulated setting must be selected so that the ComfoAir's bypass valve continues to function properly.				

Menu P7 → Reading malfunctions (and system information)

Submenu	Description	(Malfunction) information values		
		Minimum	Maximum	Standard
P70	Current software version.	Version number of the software (without "v")		
P71	Most recent malfunction.	Code in accordance with alarm and malfunction alert		
P72	Malfunction before the most recent one	Code in accordance with alarm and malfunction alert		
P73	Malfunction before the most recent two	Code in accordance with alarm and malfunction alert		
P74	Resetting a malfunction in the ComfoAir	0	1	0
P75	General reset. <ul style="list-style-type: none"> • Press "" on the CC-Ease panel or "OK" on the display for 5 seconds to carry out a general reset. All original factory settings are restored following a general reset. 	0	1	0
Note: <ul style="list-style-type: none">  After a general reset, the ComfoAir will ask you to reset the "nL / HL" (see P56) and "Li / Re" (see P57) settings.  Following a general reset, all settings in menus P2 and P3 and the programmes in P5 and P6 will need to be reset.  If the ComfoAir is fitted with a frost-free element, this must be reconfirmed in menu P51, as this setting defaults to not fitted after a general reset. 				
P76	Self-testing the ComfoAir	0	1	0
Note: Immediately after activating the self-test, the ComfoAir will run at maximum RPM. Immediately after activating the self-test, the bypass valve opens and closes. If the self-test is successful, the valve of the frost-free element opens and closes (if fitted).				
P77	Resetting filter dirty counter	0	1	0
Note: This resets the counter that triggers a dirty filter alert on the ComfoAir. This allows the filter to be cleaned or replaced before the dirty filter alert appears.				

Menu P8 → Analogue controls

Series No.	Description	(Malfunction) information values		
		Minimum	Maximum	Standard
810	Analogue input 1 0= not fitted 1 = fitted	0	1	0
811	0= controlling 1 = programming (analogue input 1)	0	1	0
812	set point analogue input 1 (programming)	0	100	50
813	min. setting analogue input 1	0	99	0
814	max. setting analogue input 1	0	100	100
815	0=positive analogue input 1 1=negative setting analogue input 1	0	1	0
816	read-out analogue input	0	100	-
850	RF input 1 0= not fitted 1 = fitted	0	1	0
851	0= controlling 1 = programming (RF input 1)	0	1	0
852	set point RF input 1 (programming)	0	100	50
853	min. setting RF input 1	0	99	0
854	max. setting RF input 1	0	100	100
855	0=positive RF input 1 1=negative setting RF input 1	0	1	0
856	Read-out RF input	0	100	-

3.8 Programming air specifications

After installation, the ComfoAir must be programmed.

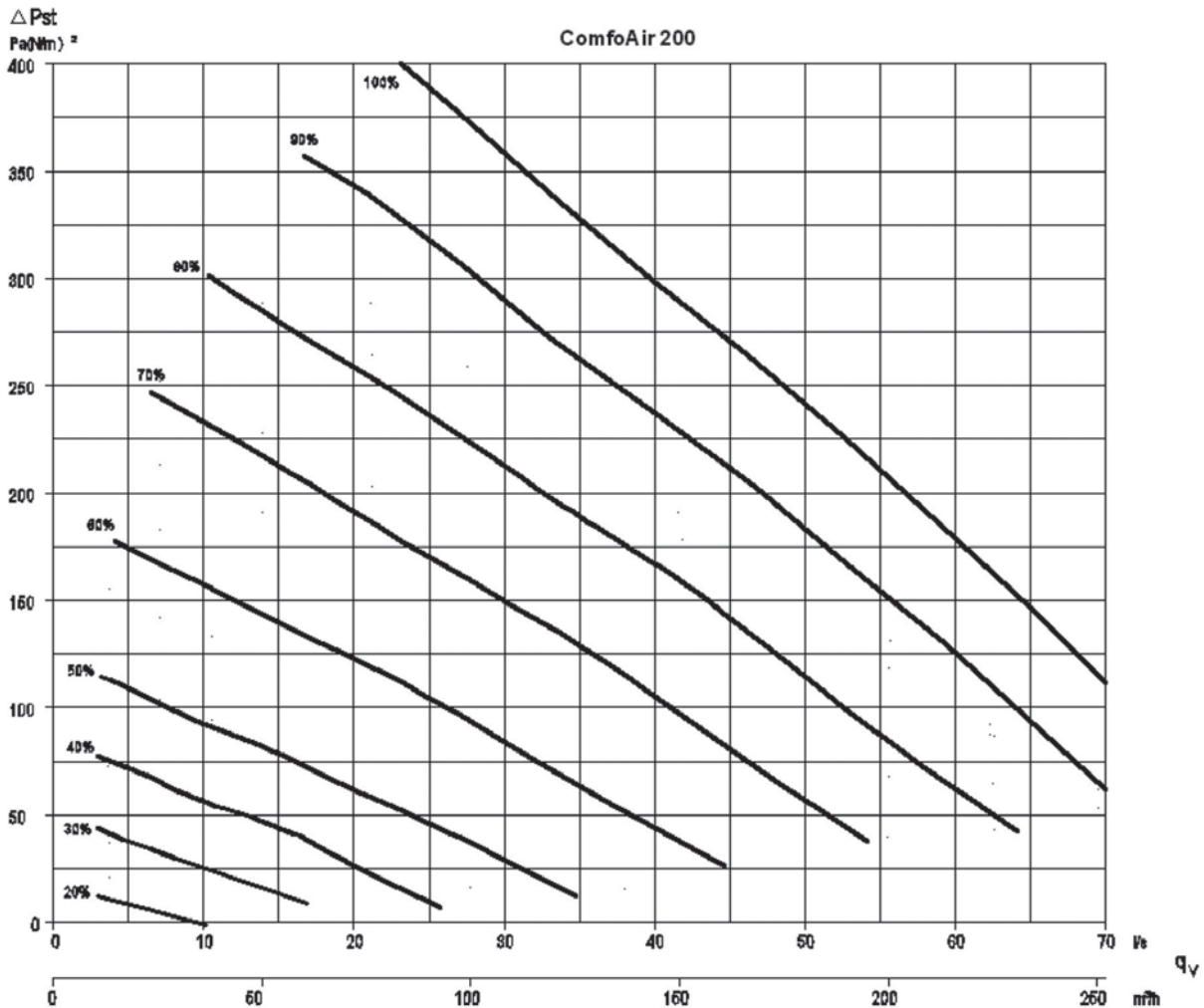

This can be done using the air specifications of the ComfoAir above.





The standard settings of the ComfoAir, nL, are:

Position ABSENT	15%
Position LOW	35%
Position MEDIUM	50%
Position HIGH	70%

The standard settings of the ComfoAir, HL, are:

Position ABSENT	15%
Position LOW	40%
Position MEDIUM	70%
Position HIGH	90%

Follow this procedure to programme the ComfoAir (after installation):

- Set the ComfoAir in programming mode.
 - Press "  " and "  " at the same time until "InR" appears on the CC Ease panel.
 - Display: Press the "  " and the "  " buttons simultaneously until "InR" is displayed.

 **In programming mode, the bypass and frost-free element valves are always closed. After 30 minutes, the ComfoAir automatically terminates the programming mode.**

- Close all windows and outside doors.
- Close all inside doors.
- Check the presence of structural overflow provisions (minimum 12 cm² per l/s).

 **The structural overflow provisions must be at least 12 cm² per l/s.**

- Check whether both fans function in the three speed settings.
- Switch the ComfoAir to high speed.
- Install all valves and set the valves according to the settings given or as set in the reference house.

If no data are known:

- Install the valves and open them as far as possible.
- Measure the air volumes; starting with the intake air and then the exhaust air.
- If the measured air volumes deviate from the nominal air volumes by more than plus or minus 10%, and the majority of the deviations is positive, ensure that all deviations are positive. If the majority of all deviations is negative, ensure that all deviations are negative. Ensure that one supply valve and one exhaust continue to be fully open.

- Change the fan settings in P menus P30 to P37 of the digital operating device.
 - Select the lowest possible setting in order to conserve energy.
 - Ensure that the ratios between low, medium and high remain equal.

 Use the chart of the ComfoAir's air specifications to set the fans.

- In the event that the currently set air volumes still deviate too much:
 - Adjust the valves.
- Check the entire installation again, after all valves have been set.
- Switch the ComfoAir (back) to ventilation position 2.

3.9 Maintenance by the installer

As a fitter of the ComfoAir, you must carry out the following maintenance:

- Inspecting the heat exchanger and fans;

A concise explanation of these maintenance activities is given in the paragraphs below.

 **Failure to carry out (periodic) maintenance on the ComfoAir ultimately compromises the performance of the ventilation system.**

3.9.1 Inspecting the heat exchanger and fans

The fans and the heat exchanger must be inspected once every 4 years.

- Disconnect the plug from the mains socket.
- Remove the filter caps from the ComfoAir.
- Release the front panel by unscrewing the screws (C).

 **The front swings forward on ceiling-mounted units.**

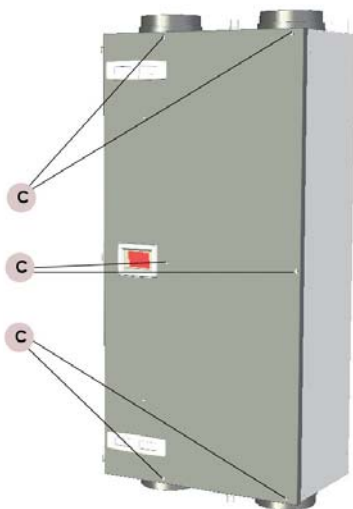

- Lift front panel from its hinges.
- Disconnect condensation drain.

 **Take care not to trap your fingers when mounting front panel.**

- Remove the leakage tray by removing the screws (D and E).

 **The heat exchanger and leakage tray may contain water!**

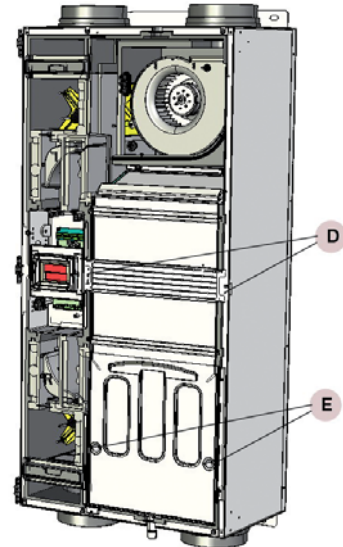

- Rotate locking nuts (G) on heat exchanger a quarter of a turn.

 **The heat exchanger may fall downwards on ceiling-mounted units, so ensure it supported when rotating the locking nuts.**

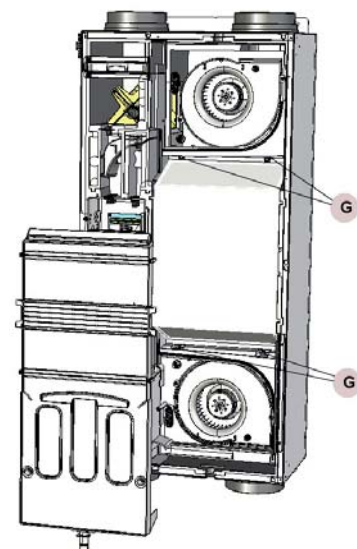

- Pull strip to remove heat exchanger (D).
- Clean the heat exchanger, if so required.
 - Submerge the heat exchanger in hot water (max. 40 °C). Do this a couple of times.
 - Rinse the heat exchanger with clean hot tap water (max. 40 °C).
 - Clasp the heat exchanger between both hands (on the coloured side surfaces) and shake the water from the heat exchanger.

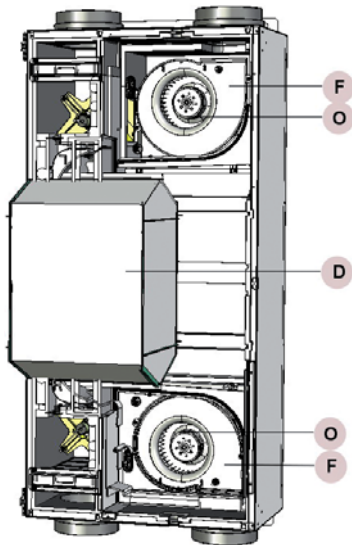

⚠ Do not use aggressive cleaning agents or solvents.

👉 Do not install the exchanger as yet the steps below explain how to remove, inspect and (if needed) clean the fans.

Do not install the heat exchanger as yet, if the fans too need to be inspected. The steps below explain how to remove, inspect and (if required) clean the fans (after cleaning the heat exchanger):

- Remove the inflow nozzle (F) by unscrewing the 2 screws surrounding the volute casing.
- Clean the fans (O).

👉 Use a soft brush to clean the fan impellers.

👉 Use a vacuum cleaner to remove dust.

⚠ Do not damage the fan impellers.

⚠ Do not damage the temperature sensor.

- Install all parts in reverse order.
- Carry out the self-test in accordance with menu P76.

👉 Check the condensation drain once every two years.

⚠ Fasten the screws to a maximum of 1.5 Nm. This is roughly equal to speed 2 of an average battery-powered drill.

3.10 Malfunctions

If the ComfoAir suffers a malfunction, then in most cases a malfunction alert will appear on the screen of the digital operating device.

However, malfunction alerts do not appear on the digital operating device in all cases, even though there is a malfunction (or problem). A concise explanation of both types of malfunction (or problem) is given in the paragraphs below.

3.10.1 Malfunction alerts on the digital operating device

Below is a list of the malfunction alerts on the digital operating device.

Code	Description
A1	NTC sensor T1 is defective. (= outside air temperature)
A2	NTC sensor T2 is defective. (= supply air temperature)
A3	NTC sensor T3 is defective. (=return air temperature)
A4	NTC sensor T4 is defective. (= exhaust air temperature)
A5	Malfunction in the bypass motor.
A6	Malfunction in the Frost-free element motor.
A7	Frost-free element does not heat sufficiently.
A8	Frost-free element becomes too hot
E1	Exhaust fan not rotating (M1).
E2	Supply fan not rotating (M2).
EA1	Enthalpy sensor measures excessive RH values.
EA2	No communication with the enthalpy sensor.
NC	No communication with the ComfoAir

⚠ Prevent water from entering the electrical connections.

3.10.2 Trouble shooting

Below are a number of trouble-shooting tips for the malfunction alerts described above, such as can appear on the digital operating device in the event of a malfunction.

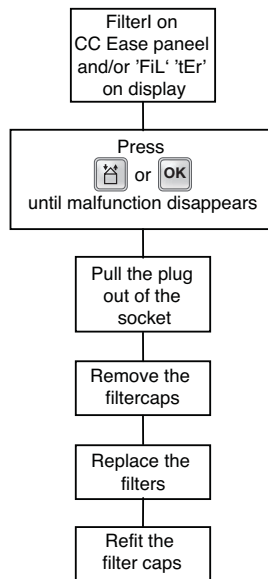

ATTENTION!
Risk of electrocution:
do not touch the PCB
or the reheater.

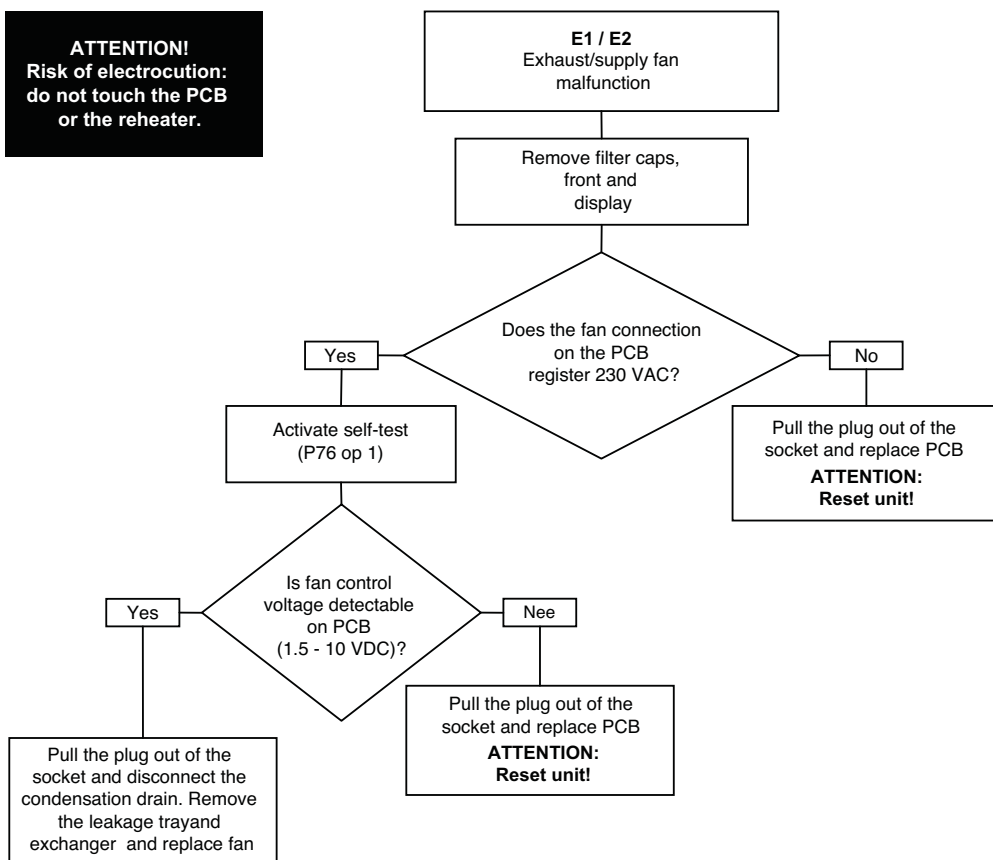

ATTENTION!
Risk of electrocution:
do not touch the PCB
or the reheater.

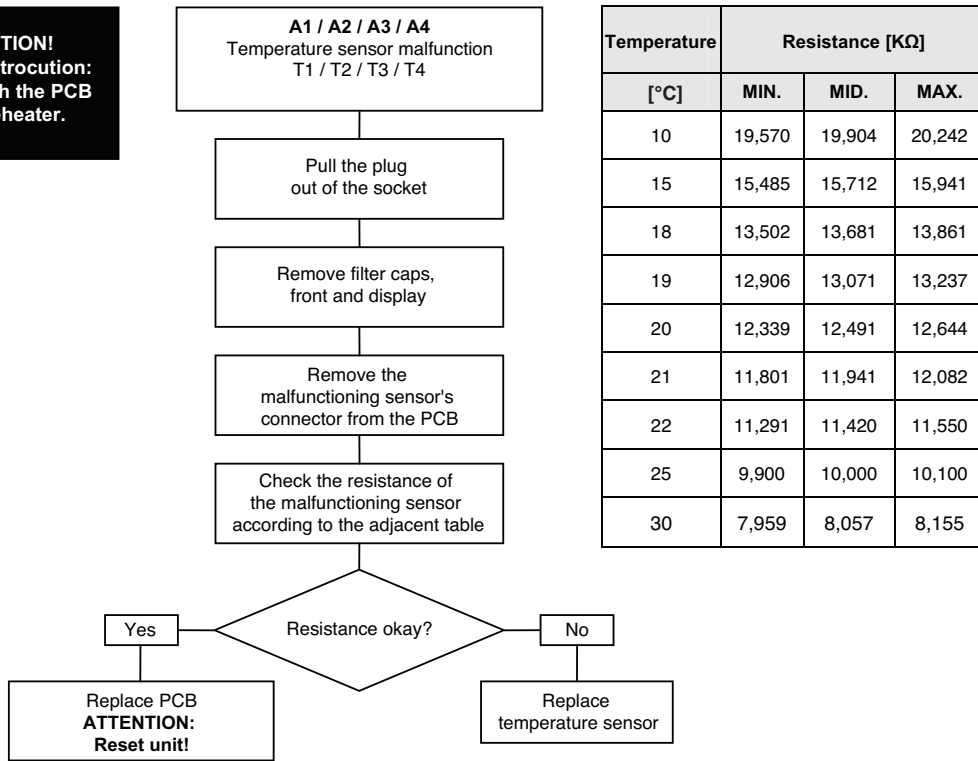

ATTENTION!
Risk of electrocution:
do not touch the PCB
or the reheater.

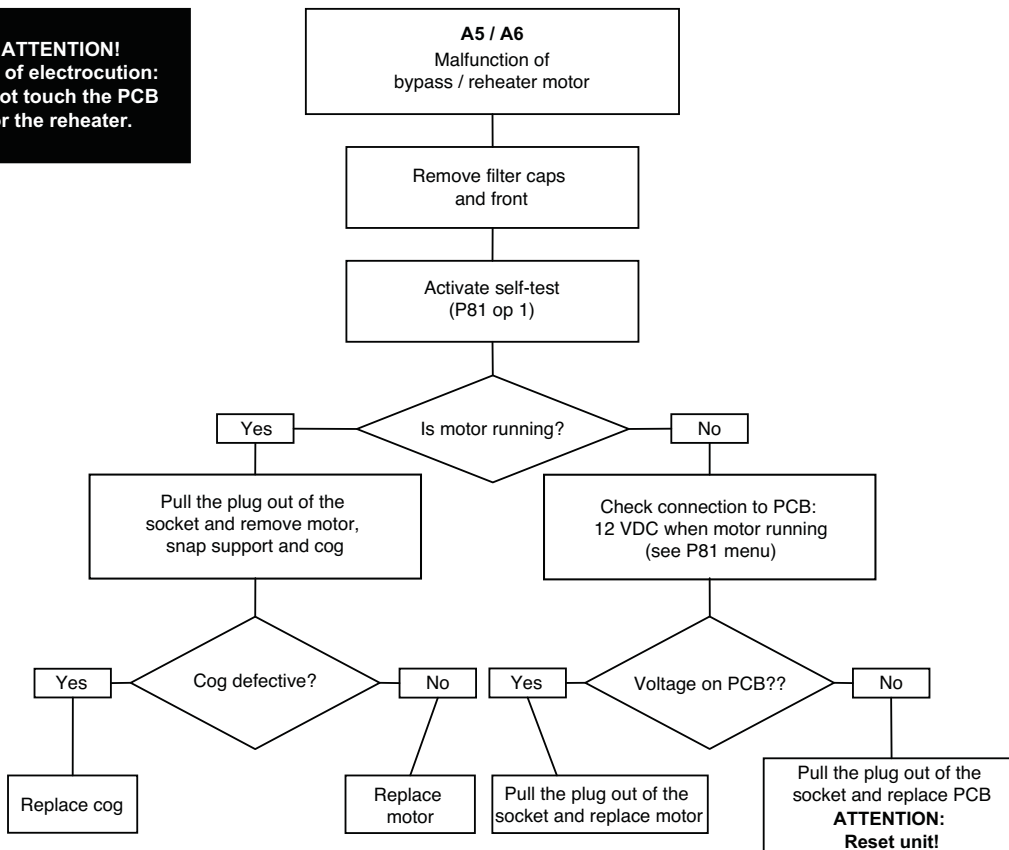

ATTENTION!
Risk of electrocution:
do not touch the PCB
or the reheater.

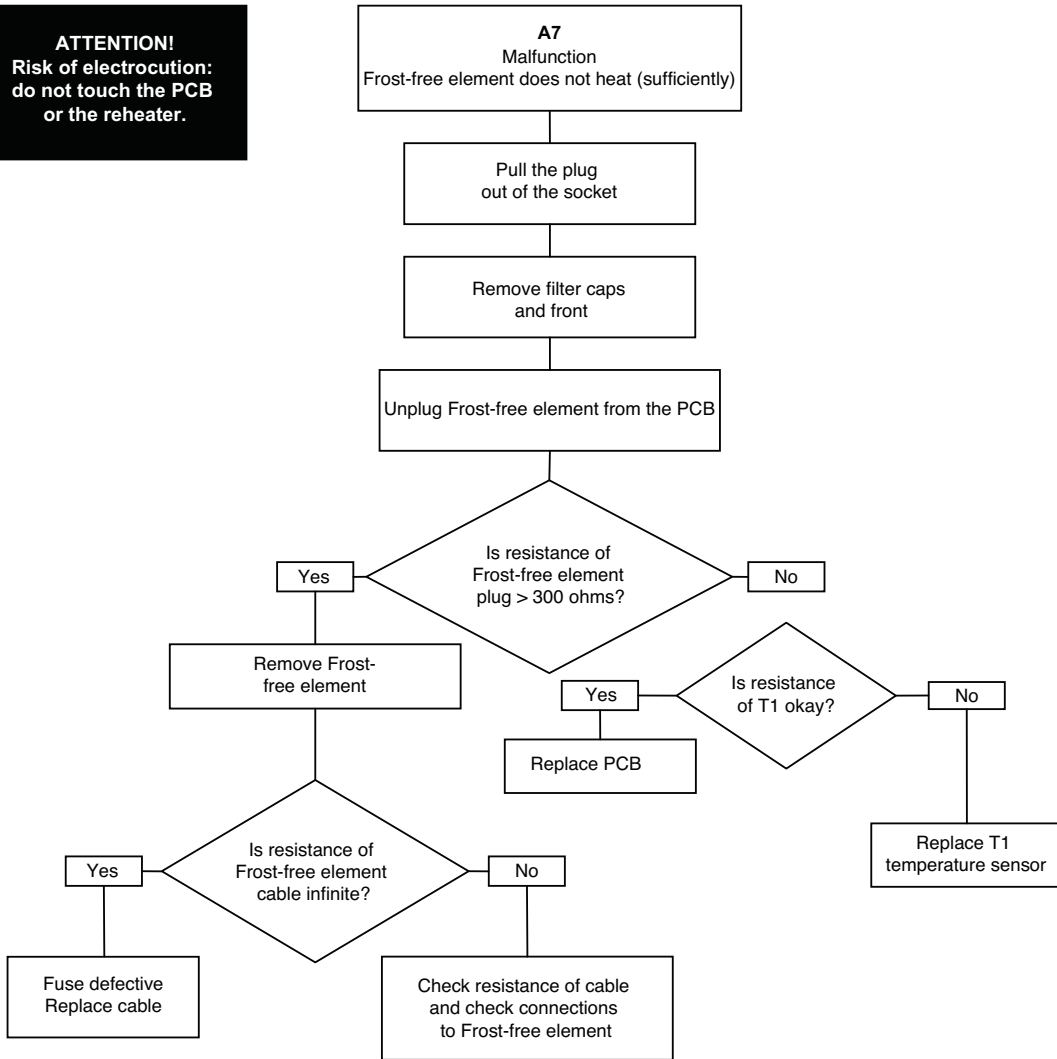

ATTENTION!
Risk of electrocution:
do not touch the PCB
or the reheater.

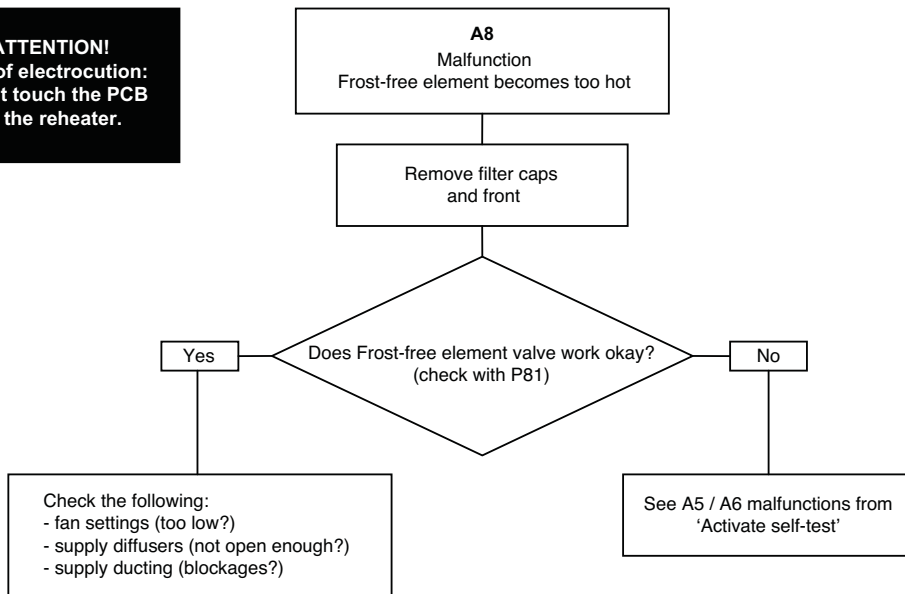

3.10.3 Malfunctions (or problems) without alerts

An overview of the malfunctions (or problems) without notifications is given below.

Problem/Malfunction	Indication	Check / action
System switched off	Power supply on	Check the fuse on the PCB panel. • If the fuse is OK, the control print is defective.
	No power supply	Mains power is off.
High intake temperature in summer	Bypass remains closed	Reduce the comfort temperature.
Low intake temperature in winter	Bypass stays open	Increase the comfort temperature.
Little or no air supply; shower remains damp	Filters blocked	Replace the filters.
	Valves blocked	Clean the valves.
	Exchanger clogged by dirt.	Clean the exchanger.
	Exchanger frozen	Defrost the exchanger.
	Fan dirty	Clean the fan.
	Ventilation ducts blocked	Clean the ventilation ducts.
	ComfoAir is in frost-protection mode	
Too noisy	Fan bearings defective	Replace the fan bearings.
	Fan settings	Change the fan settings.
	Slurping noise • Siphon is empty • Siphon does not seal properly	Reconnect the siphon.
	Whistling noise • An air gap somewhere	Seal the air gap.
	Airflow noise • Valves do not close onto duct. • Valves not open far enough	Reinstall the valves. Reset the valves.
Condensation leak	Condensation drain clogged	Unblock the condensation drain.
	Condensation from exhaust duct does not run into leakage tray	Check whether the connections are correct.
Corded 3-position switch not working	Cabling is Not good	Check the wire-circuit of the 3-position switch by measuring the voltage: • Voltage only on N & L3: [Fans rotate in position 1]. • Voltage only on N & L3 & L2: [Fans rotate in position 2]. • Voltage only on N & L3 & L1 or N & L3 & L2 & L1: [Fans rotate in position 3].
	Switch is defective	
Cordless 3-position switch not working	Battery is empty	Check the battery. • Replace the battery (if necessary).

3.11 Service parts

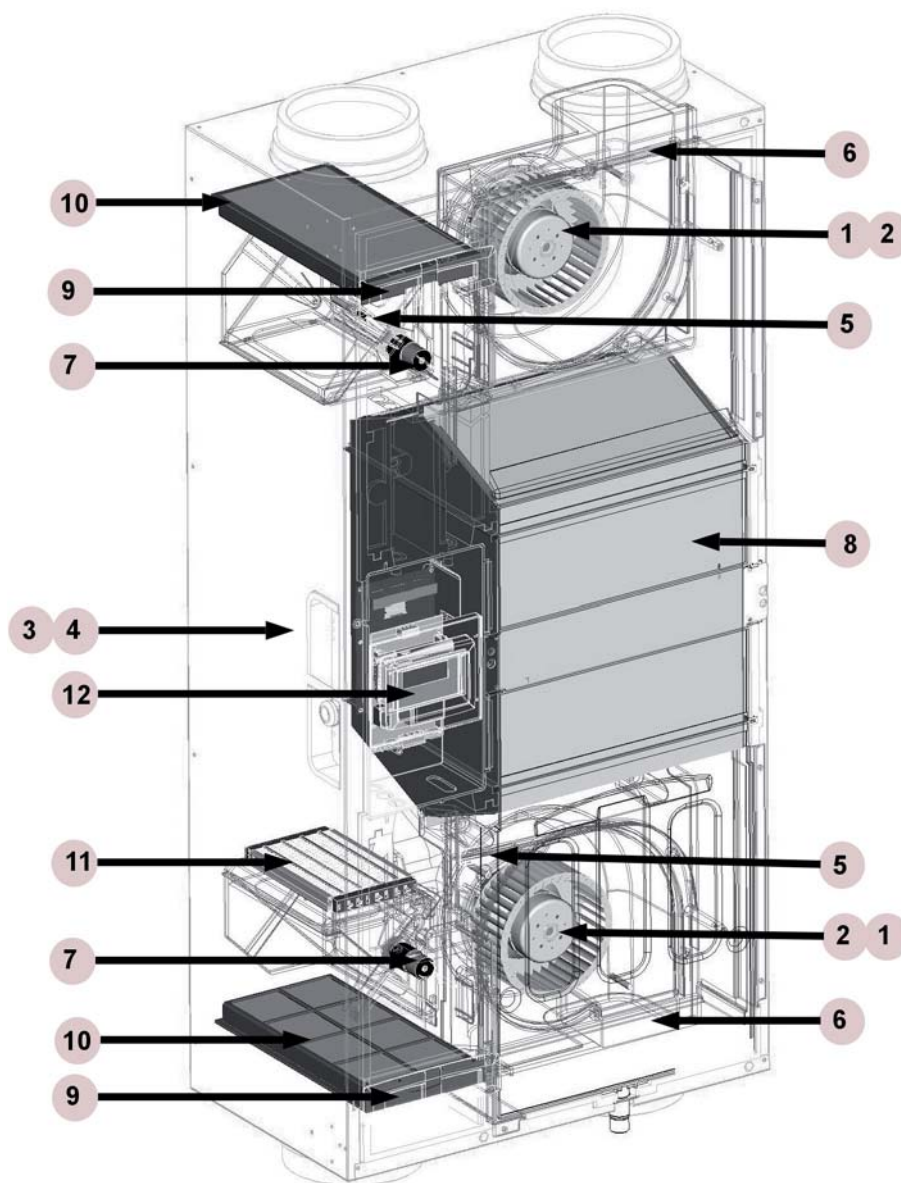

The following table contains an overview of the spare parts available for the ComfoAir.

Number	Part	Article number
1	Fan Right-hand (Green)	400200018
2	Fan Left-hand (Red)	400200019
3	ComfoAir PCB; basic or luxury version	400300051
4	Connector panel	400300031
5	Temperature sensor T1 / T3	400300049
6	Temperature sensor T2 / T4	400300048
7	Servo motor & cable (for the bypass and the Frost-free element)	400300015
8	Heat exchanger	400400012
9	Filter cap	
10	Filter	400100014
11	Frost-free element (also available as an optional kit for subsequent installation)	400300060
12	Display	400300020

3.12 Wiring diagram:
ComfoAir 200 – LEFT-HAND version

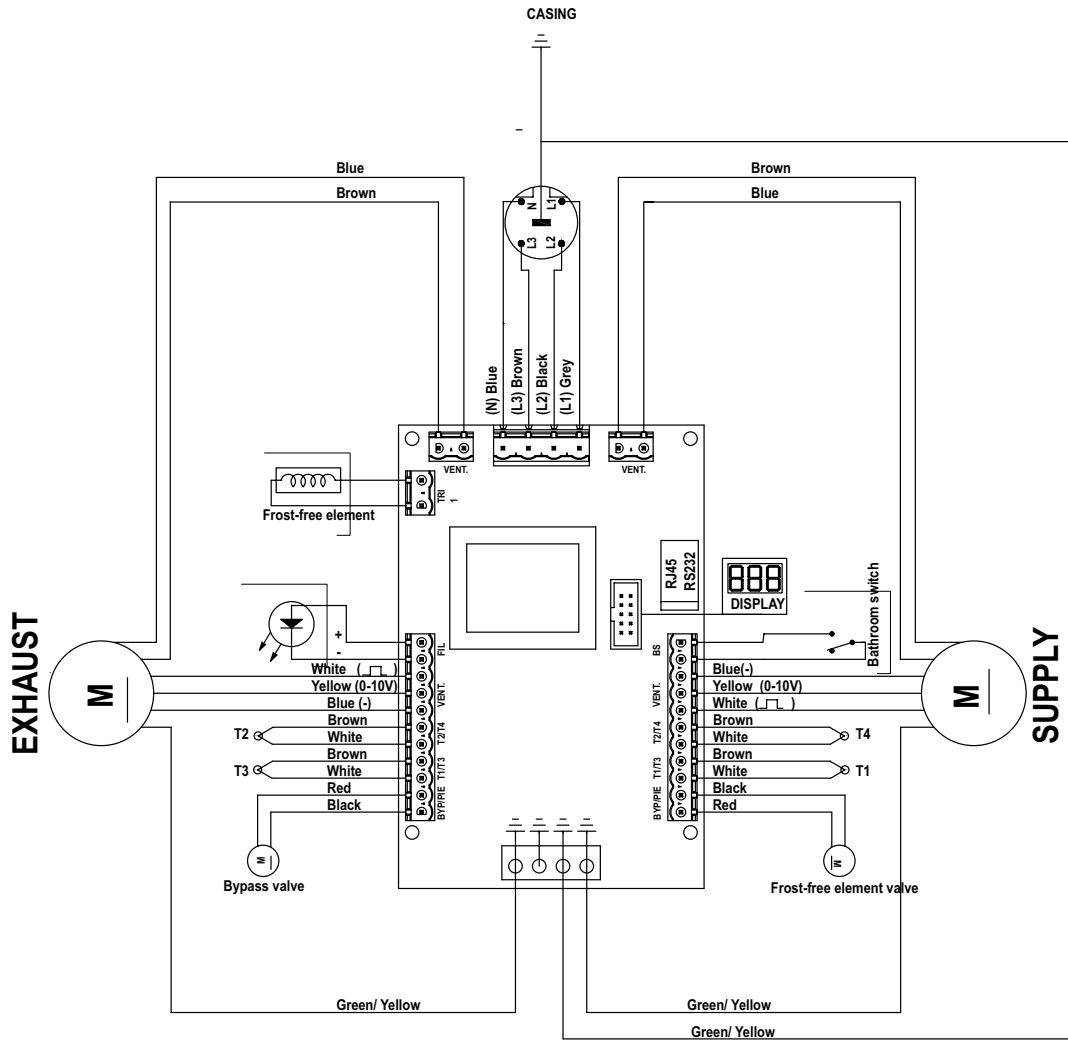

3.13 Wiring diagram:
ComfoAir 200 – RIGHT-HAND version

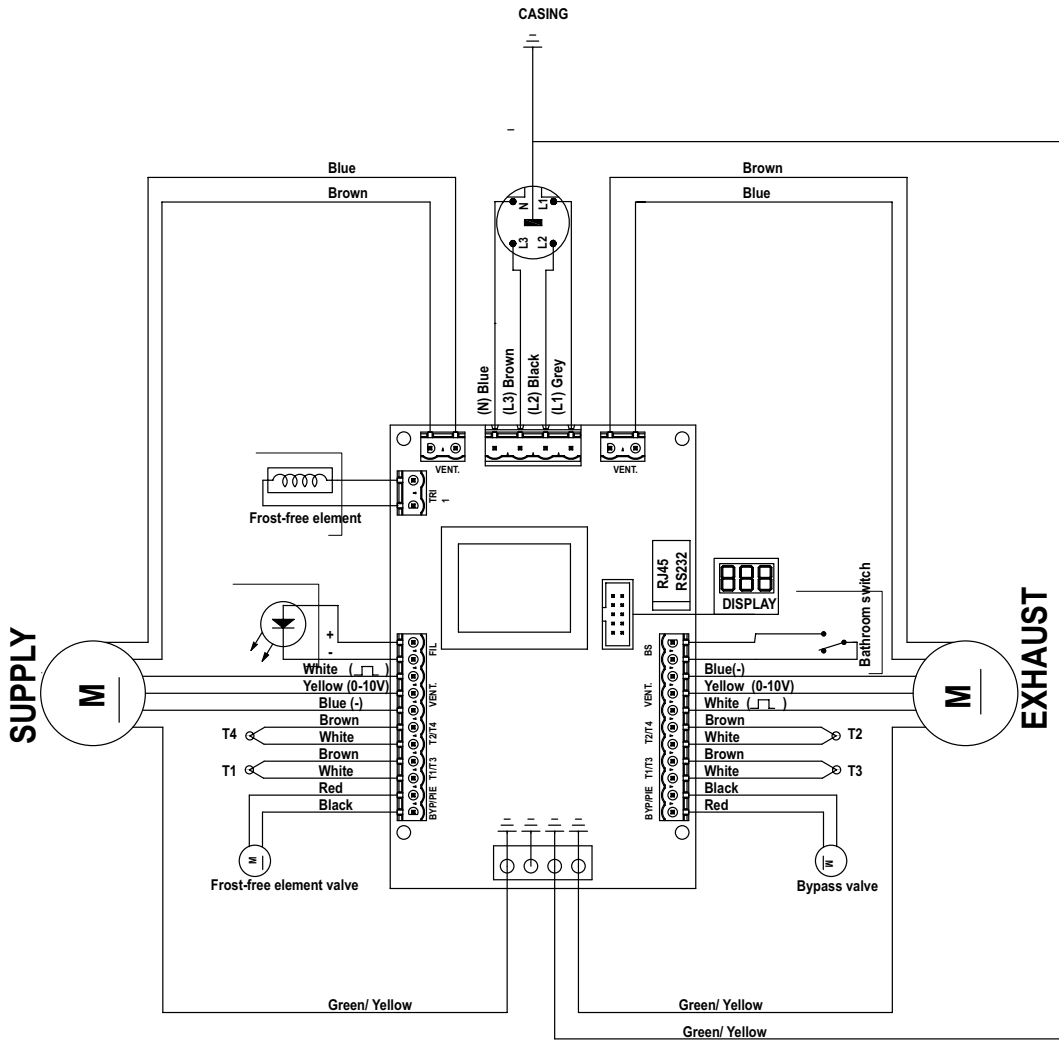

3.14 Wiring diagram:
ComfoAir 200 Luxe – LEFT-HAND version

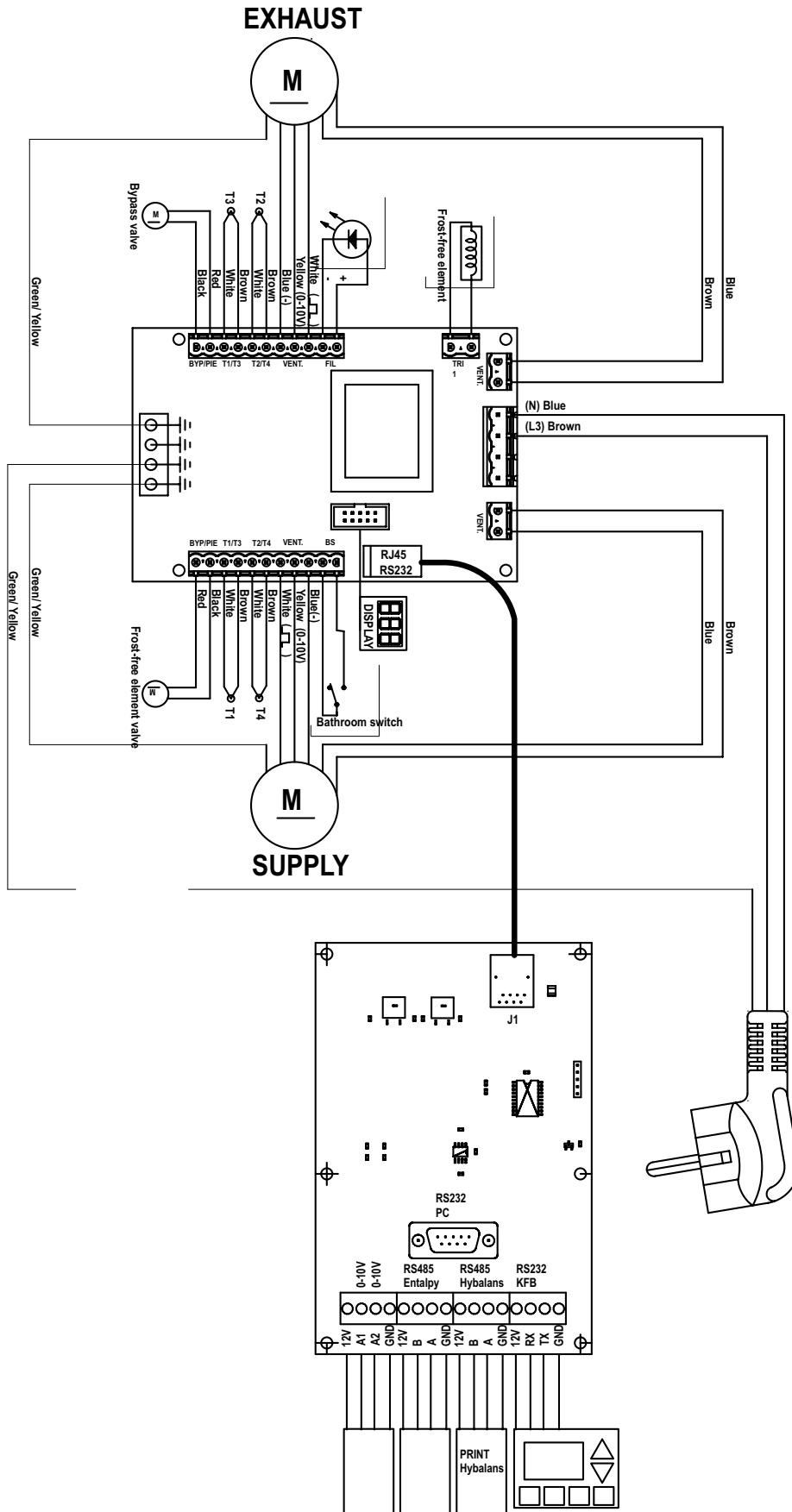

**3.15 Wiring diagram:
ComfoAir 200 Luxe – RIGHT-HAND version**

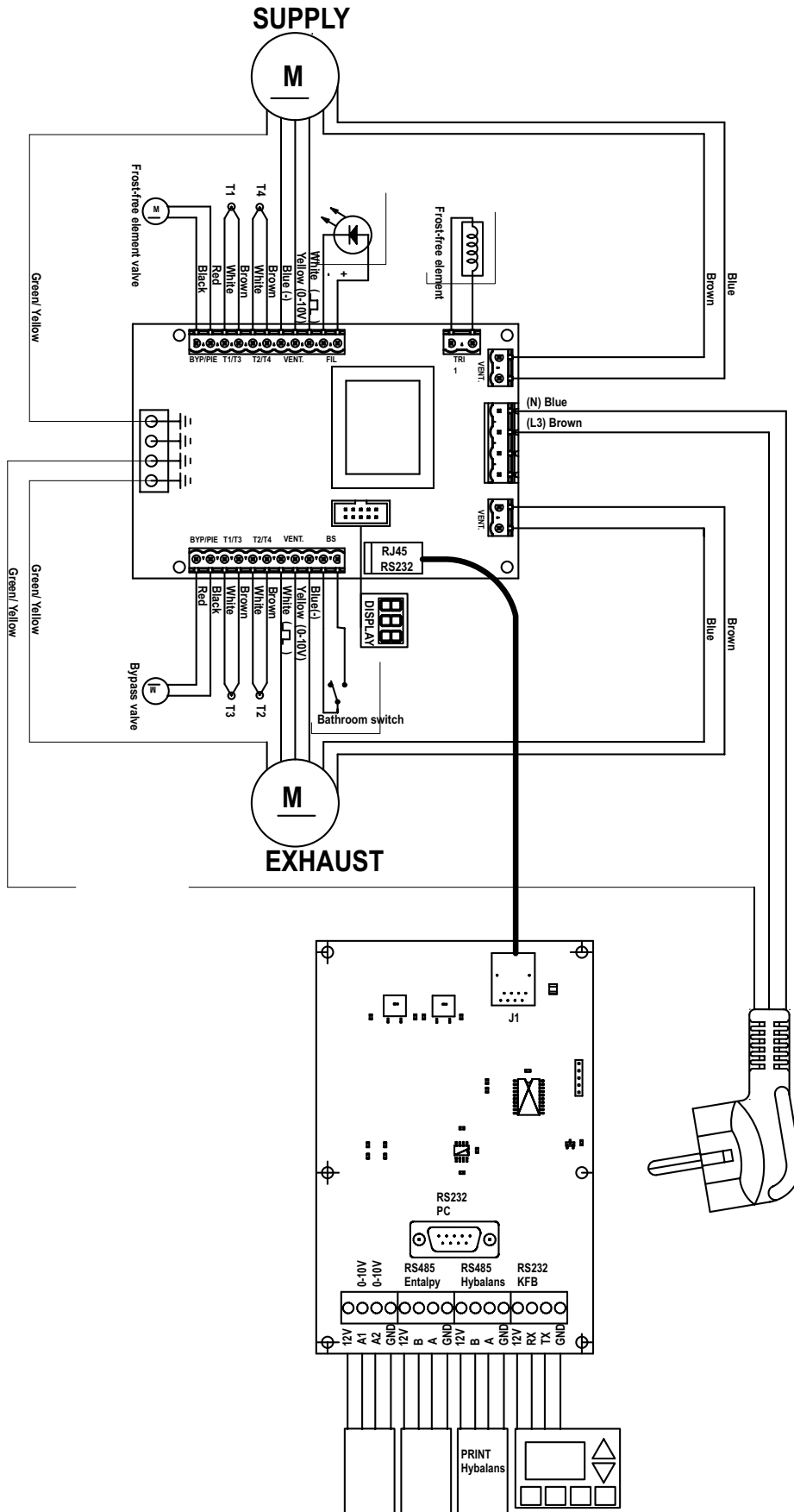

EC declaration of conformity

J.E. Stork Ventilatoren B.V.
Lingenstraat 2
8028 PM Zwolle-NL
Tel.: +31 (0)38-4296911
Fax: +31 (0)38-4225694
Company register Zwolle 05022293

EG declaration of conformity

Machine description : Heat recovery units: ComfoAir 200 series

Complies with the following directives : Machinery Directive (98/37/EG)
Low Voltage Directive (2006/95/EG)
EMC Directive (204/108/EG)

Zwolle, 5 February 2008
J.E. Stork Ventilatoren B.V.



E. v. Heuveln,
Managing Director

comfosystems

zehnder

J.E. Stork Ventilatoren B.V.

Lingenstraat 2
8028 PM Zwolle
Nederland

Tel.: (038) 429 69 11

Fax.: (038) 422 56 94

Internet: www.jestorkair.nl

E-mail: info@jestorkair.nl